

Methodology for the Calculation of Scheduled Exchanges resulting from single day-ahead coupling – Explanatory Note

21 February 2018

Disclaimer

This explanatory document is approved by All TSOs, submitted to all NRAs by All TSOs, for information and clarification purposes only accompanying the DA Scheduled Exchanges Calculation Methodology in accordance with Article 43 of the Regulation 2015/1222 of 24 July 2015 establishing a Guideline on Capacity Allocation and Congestion Management

Table of Contents

1. Introduction	4
1.1 Purpose and Structure of the Methodology	4
1.2 Development of the Methodology.....	4
1.3 TSOs interpretation about the exchanges between NEMO Trading Hubs	5
1.4 Current Situation.....	6
2. Common Criteria for Scheduled Exchanges Calculation	7
3. Requirements for Scheduled Exchanges Calculation	7
4. Downstream Uses for Scheduled Exchanges	8
4.1 Shipping & Scheduling.....	9
4.2 Congestion Income Distribution	10
5. Scheduled Exchange Calculator	11
5.1 Calculation process.....	11
5.2 Time Limits for Delivery of Information	12
6. Calculation Methodology.....	13
6.1 General Principles.....	13
6.2 Flow calculation between Bidding Zones (BZ).....	18
6.3 Calculation of Scheduled Exchanges per Scheduling Area border.....	20
7. Implementation	21
ANNEX 1 - Functioning principles of the SDAC under MNA, Description of the Inter-NEMO Flow Calculation	23
Description Flow Calculation between NEMO Trading Hubs (NTHs).....	24
ANNEX 2 – Functioning principles of the SDAC under MNA	27
1. Purpose of the document	30
2. Glossary	30
3. Euphemia MNA coupling process	32
3.1 Euphemia perspective on sequence of the coupling calculation process	32
3.2 Functioning of the order aggregation	33
3.3 Zonal calculation.....	35
3.4 Functioning of the order de-aggregation	35
3.5 Functioning and coherence of the 3 flow calculation steps.....	35
3.5.1 Flow calculation between Bidding Zones (BZ).....	37
3.5.2 Flow calculation between Scheduling Areas (SA)	40
3.5.3 SEC Backup calculation process (degraded mode)	44
3.5.4 Rounding solution	50
3.6 Solution validation.....	55
3.7 Change Control.....	55

4.	Procedures	57
4.1	Normal Procedures	57
4.2	SEC Degraded Mode	58
4.3	Decoupling Procedures.....	58
5	PMB requirements	60
5.1	Shared Configuration file changes	61
5.2	CZC submission	62
5.2.1	Cross-check modes	62
5.2.2	Network data validation GUI	64
5.3	Order data submission.....	64
5.4	Interface changes towards algorithm.....	65
5.4.1	Order Data.....	65
5.4.2	Results.....	65
5.4.3	Tie break rules between blocks.....	65
5.5	Show Results GUI.....	65
5.6	Results document	65
5.7	Identification codes of BZ, SA, NH and Tie lines	65
5.8	Changes in PBM due to decoupling	66
	ANNEX 3 - List of comments received	67

Table of Figures

Figure 1:	Current situation.....	6
Figure 2:	Downstream Uses for Scheduled Exchanges.....	9
Figure 3:	Exchanges of Schedules,.....	10
Figure 4:	Proposed process by PCR	12
Figure 5:	Stepwise approach for the calculation of schedules	14

Table of Equations

Equation 1.....	15
Equation 2.....	18

1. Introduction

1.1 Purpose and Structure of the Methodology

Article 43(1) of the Commission Regulation 2015/1222 establishing a Guideline on Capacity Allocation and Congestion Management (hereinafter referred to as ‘CACM Regulation’) requires that, by 16 months after the entry into force of CACM Regulation, all Transmission System Operators (“TSOs”) which intend to calculate Scheduled Exchanges resulting from single day-ahead coupling shall develop a proposal for a common methodology for this calculation.

The common calculation methodology (hereinafter referred to as “DA SEC Methodology”) shall be subject to approval by all National Regulatory Authorities (“NRAs”) as per Article 9.7(d) of the CACM Regulation. According to Article 9(9) of the CACM Regulation, the DA SEC Methodology proposal shall be submitted to ACER in parallel with the submission to all NRAs. ACER may issue an opinion on the DA SEC Methodology only if requested by the NRAs.

This document is an explanatory note accompanying the DA SEC Methodology, describing the technical background which forms the basis for the methodology. The document is structured as follows. The legal requirements for the DA SEC Methodology and their implications are presented in Chapter 2. Chapter 3 provides the list of information required from the relevant NEMOs. In Chapter 4 the uses of Scheduled Exchanges are described and Chapter 5 introduces the establishment of the Scheduled Exchange Calculator. The calculation methodology is explained within Chapter 6. Finally, Chapter 7 describes the plan for implementation of the DA SEC Methodology. In annexes 1 and 2 are the functioning principles of the Single Day Ahead Coupling under Multi-NEMO Arrangements.

Capitalised terms used in this document are understood as defined in CACM Regulation, Regulation (EC) No 714/2009 of the European Parliament and of the Council of 13 July 2009 on conditions for access to the network for cross-border exchanges in electricity (hereafter referred to as “Regulation (EC) No 714/2009”), Commission Regulation (EU) 543/2013, Article 3 of Regulation (EU) 2017/1485 and the DA SEC Proposal.

1.2 Development of the Methodology

The Interim NEMO Committee has created a MNA task force under PCR to analyse the scope and define the requirements of the new version of the DA algorithm (Euphemia release 10.3) to develop the Multi NEMO Arrangements (MNA) functionalities, especially calculation of Net Positions per NEMO Trading hub and determination of flows between NEMO Trading hubs (so called NEMO Trading Hub flows).

Following the All TSOs ‘decision of the 25 August 2017, only one Scheduled Exchanges Calculator will be established and this Scheduled Exchanges Calculator will be developed within PCR. This is also part of the MNA implementation work.

TSOs and NEMOs have worked together in order to elaborate the functioning principles on which the development of the solution will be based. The collaboration ensures consistency between all levels of the calculations (bidding zone border, scheduling area border and exchanges between NEMO Trading Hubs). The calculation of the Scheduled Exchanges between bidding zones and scheduling areas described in this Methodology reflects the principles agreed by all TSOs and all NEMOs.

Following the public consultation in November 2017, the DA SEC methodology has been significantly reworked with regards to structure and content, addressing most of the comments raised. The concept of Scheduled Exchanges between NEMO Trading Hubs was not elaborated despite in this DA SEC Methodology. This action is justified in section 1.3.

1.3 TSOs interpretation about the exchanges between NEMO Trading Hubs

To ensure a proper functioning of Multi-NEMO Arrangement in line with Article 45 of the CACM Regulation, TSOs agree that the concept of NEMO Trading Hub is needed, and that it is needed to define flows between NEMO Trading Hubs.

TSOs believe that it should be NEMOs' responsibility to calculate exchanges between NEMO Trading Hubs. In the feedback from the public consultation in November 2017, NEMOs confirmed the same understanding that exchanges between NEMO Trading Hub should be NEMOs' responsibilities. Therefore, NEMOs requested TSOs to remove all the parts from the DA SEC Methodology mentioning NEMO Trading Hub.

According to TSOs, one option would be to include the requirement of exchanges between NEMO Trading Hub in the scope of Article 77 of the CACM regulation about the clearing and settlement costs.

In the CACM regulation, "Scheduled Exchange" means an electricity transfer scheduled between geographic areas, for each market time unit and for a given direction.

The NEMO Trading Hub is not equal to a geographic area. Therefore, the Scheduled Exchanges Methodology required by Article 43 of the CACM Regulation does not concern NEMO Trading Hubs.

The DA SEC Proposal is thus in line with the CACM regulation and does not provide for the calculation of exchanges per NEMO Trading Hub as NEMO Trading Hubs are not geographic areas.

Nevertheless, it is essential that the exchanges between NEMO Trading Hubs are consistent with the Scheduled Exchanges between bidding zones and Scheduled Exchanges between scheduling areas calculated by Scheduled Exchange Calculator and described in DA SEC Methodology. This

consistency is already ensured in the functioning principles for the SDAC under MNA (Euphemia Release 10.3), approved by all NEMOs and all TSOs.

Furthermore, the calculation of exchanges between Nemo Trading Hubs shall be compliant with the local Multi Nemo Arrangements in accordance to Article 45 of the CACM Regulation. This consistency is also already ensured in the functioning principles for the SDAC under MNA (Euphemia Release 10.3), approved by all NEMOs and all TSOs.

1.4 Current Situation

In order to create a clear and comprehensive understanding of the requirements laid out in Article 43 of the CACM Regulation, the document provides description of current situation across Europe.

The majority of TSOs across Europe applying the Coordinated Net Transmission Capacity approach, currently use the allocated capacities in the form of scheduled flows resulting from the day-ahead market coupling algorithm. These scheduled flows are used as Scheduled Exchanges between bidding zones to feed into the shipping, scheduling and congestion income distribution processes.

A subset of the TSOs of the ‘CORE’ region applying the flow based approach (former CWE region) perform a separate calculation of Scheduled Exchanges, using the net positions resulting from the market coupling algorithm as an input for the scheduled exchange calculation, in order to introduce Scheduling Restrictions, namely intuitiveness, which is required to ensure that Scheduled Exchanges are defined from low price to high price areas.

As Figure 1. shows, PCR is currently fulfilling the flow calculation on behalf of all non-CWE TSOs, while CWE is fulfilling its own scheduled exchange calculation.

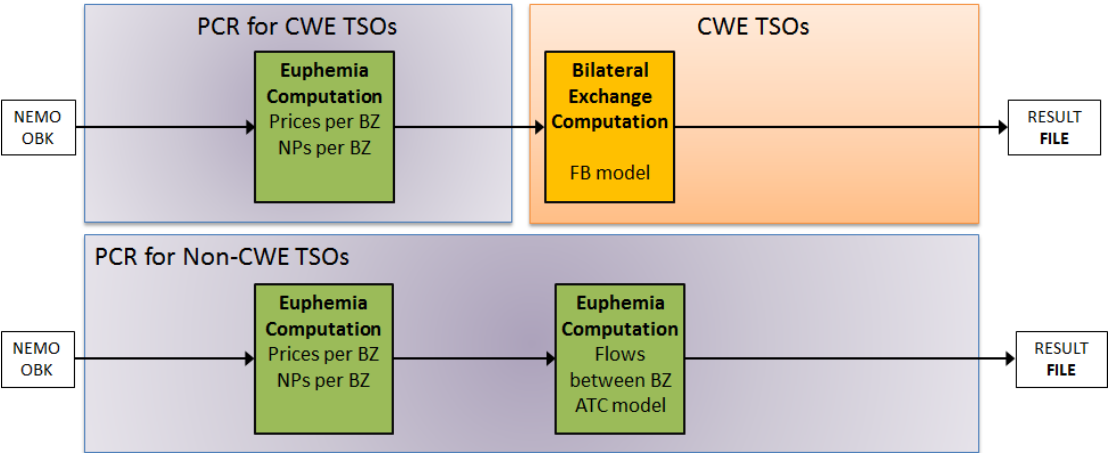

Figure 1: Current situation

From the implementation of the Multiple NEMO Arrangement (MNA) onwards, CWE TSOs shall no longer calculate Scheduled Exchanges. The flow calculation for CWE will be fulfilled by PCR (see 1.2 and 5.1)

2. Common Criteria for Scheduled Exchanges Calculation

Article 43(1) of the CACM Regulation makes a reference to "TSOs which intend to calculate scheduled exchanges" to submit the DA SEC Proposal. However, pursuant to the request of the national regulatory authorities, all TSOs have joined the DA SEC Proposal for the requirements to calculate Scheduled Exchanges resulting from single day-ahead coupling, the information required from all NEMOs for the calculation, the setup of the Scheduled Exchange Calculator, the calculation process, methodology and description of the required equations.

To achieve the targets set in the CACM Regulation to promote the completion and efficient functioning of the internal market and ensure the optimal management, coordinated operation and sound technical development of the electricity transmission system in Europe, EC, TSOs and ENTSO-E acknowledge the importance of involving non-EU TSO members of ENTSO-E, especially the ones responsible for electricity systems physically connected to EU Member States, in the development of this proposal. This was ensured by providing the opportunity for non-EU TSO members of ENTSO-E to participate in the development of the proposal.

3. Requirements for Scheduled Exchanges Calculation

Articles 3 of the DA SEC Proposal introduce a list of information which shall be provided by the relevant NEMOs.

Article 43(2) of the CACM Regulation stipulates that the DA SEC Methodology proposal shall 'list the information which shall be provided by the relevant NEMOs to the Scheduled Exchange Calculator'. As per Article 43(3) of the CACM Regulation, the Scheduled Exchange calculation shall be based on net positions for each market time unit. According to Article 48(1)(a) of the CACM Regulation, all NEMOs performing MCO functions shall deliver the single day-ahead coupling results to all TSOs, all coordinated capacity calculators and all NEMOs. At least these results should be:

- A single clearing price for each Bidding Zone and market time unit in EUR/MWh
- A single net position for each Bidding Zone and each market time unit

Therefore, all NEMOs shall provide the following information, resulting from the single day-ahead coupling to the Scheduled Exchange Calculator and all TSOs, for each market time unit, in order for the Scheduled Exchange Calculator to perform the DA Scheduled Exchanges Calculation:

- Unrounded net position per Scheduling Area;
- Unrounded net position per Bidding Zone;
- A single clearing price for each Bidding Zone and market time unit in EUR/MWh

- Allocated capacities in form of Scheduled Flows for each bidding zone border

The information requirements listed above are essential for both, the calculation of Scheduled Exchanges by the Scheduled Exchange Calculator and the post calculation verification tasks, to ensure, that the aggregated sum of all Scheduled Exchanges per Bidding Zone or Scheduling Area border is equal to the net position of that Bidding Zone or Scheduling Area.

These information requirements are also in line with the All NEMOs' proposal for the price coupling algorithm in accordance with Article 37 (5) of the CACM Regulation.

In general, DC network elements shall use the output of the Day Ahead coupling processes (allocated capacities, in the form of Scheduled Flow into and out of individual relevant DC network elements (difference in flows in/out reflecting losses where applicable)) rather than a separate Scheduled Exchange Calculation Methodology. For example, this is the implementation planned for the SEM-GB¹ border where there are two DC network elements on the same bidding zone border. The relevant NEMO(s) will provide an output from Day Ahead algorithm post-processing reflecting the flows on each DC network element relative to each bidding zone. The difference between the bidding zone values will reflect the different loss factors on each DC network element. The implementation also ensures validation of the data through related processes such as results verification.

For cross border DC interconnectors within an area applying flow based and where the impact of an exchange over the DC Interconnector is considered during flow based allocation, the Scheduled Exchanges over the respective bidding zone border may differ from the Scheduled Flow over the interconnector. This allows, if configured as such, a calculation based only on net positions of the scheduling area and bidding zone, a set of constraints and allocated capacities in the form of Scheduled Flows on relevant bidding zone borders (as for other AC interconnectors).

4. Downstream Uses for Scheduled Exchanges

There are three identified uses for Scheduled Exchanges (resulting from either single day-ahead or intraday coupling) as shown in Figure 2 below.

¹ SEM-GB: Borders Great Britain-Ireland and Great Britain-Northern Ireland

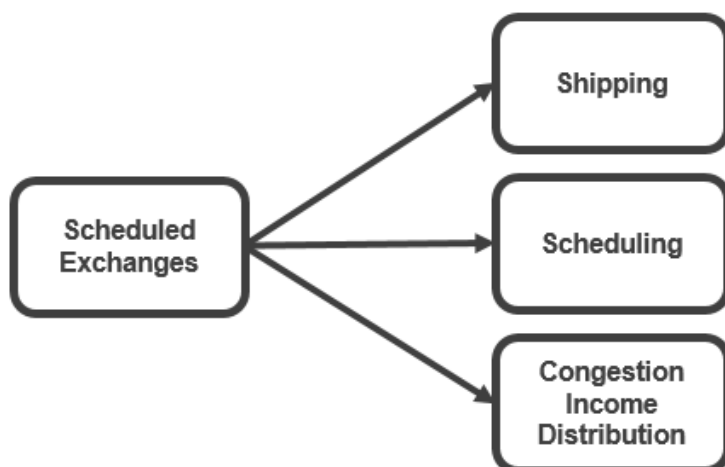

Figure 2: Downstream Uses for Scheduled Exchanges

4.1 Shipping & Scheduling

Scheduled Exchanges serve as a basis for the shipping process, in which financial (commercial) and physical exchanges take place on the respective Bidding Zone or Scheduling Area border. Tasks related to cross-border physical and financial shipping could be performed together or separately by any legal entity, which could be different entities on each border, i.e. by CCPs or Scheduling Agents (of a Shipping Agent).

- Physical shipping in general means the task of transferring net positions between different Central Counter Parties in different scheduling areas in a form of Scheduled Exchange. The Scheduled Exchange is equal to the net position as long as no other additional bilateral exchanges (in AC and/or DC) for this scheduling area and for this market coupling process occur. The Shipping process may consist of local (internal) and cross-border (external) shipping phase.
- Financial shipping means all activities related to the financial clearing and settlement of Scheduled Exchanges between two different Central Counter Parties. Shipping fees and congestion income are based on this shipping information.

According to Article 8(2g) of the CACM Regulation, the TSOs shall establish Schedule Exchange Calculators for calculating and publishing Scheduled Exchanges on borders between Bidding Zones. Upon completion of the Scheduled Exchanges calculation, the Scheduled Exchange Calculator, in line with Articles 8, 49 and 61 of the CACM Regulation, shall notify relevant NEMOs, central counter parties, shipping agents and TSOs of the agreed Scheduled Exchanges.

According to Article 2(43) of the CACM Regulation, the shipping agent's role is to transfer the net position(s) between different central counter parties.

A separate role ‘Scheduling agent’ is required to notify (or nominate) schedules to TSOs. This creates a link between the market operation and the system operation. Figure 3 below illustrates the role of the scheduling agent in relation to the CCPs and the shipping agents.

Both the internal commercial trade schedules between shipping agents and CCPs and the internal commercial trade schedules between shipping agents and other shipping agents are nominated to the TSOs responsible for operating the scheduling area. In addition, the external commercial trade schedules are nominated to the TSOs operating the scheduling area, by the scheduling agents of the shipping agents, as Scheduled Exchanges between the scheduling area and another scheduling area;

Scheduled Exchanges determine the volumes to be settled between NEMOs both physically and financially. This means that Scheduled Exchanges determine the cross-border nominations to be taken into account by TSOs.

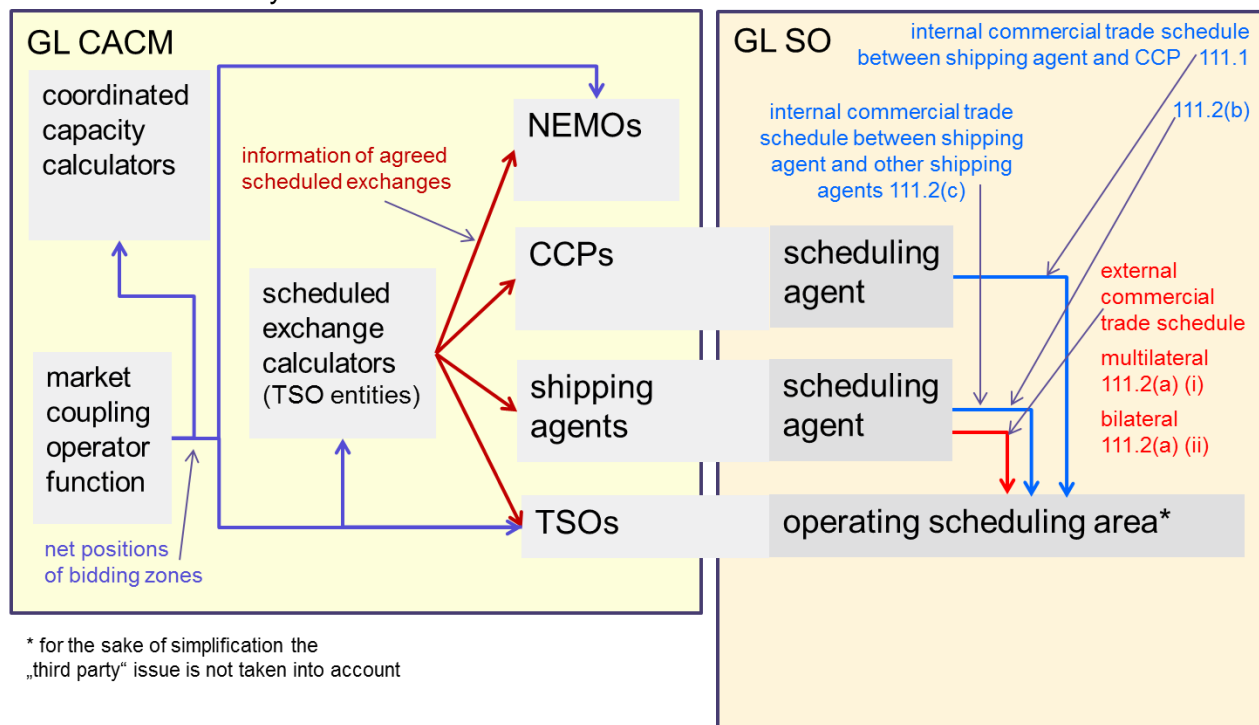

Figure 3: Exchanges of Schedules^{2,3}

4.2 Congestion Income Distribution

In CACM Regulation, Congestion Income is defined as “the revenues received as a result of capacity allocation”. Congestion Income originates in the situation where transmission capacity between Bidding Zones or on Critical Network Elements is not sufficient enough to fulfil the demand.

² SO GL stands for the COMMISSION REGULATION (EU) 2017/1485 of 2 August 2017 establishing a guideline on electricity transmission system operation

³ References to 111.1 and 111.2 relate to Articles 111 of the System Operations Guideline. The references are required in order to clearly illustrate the links between the CACM Regulation and the SO GL

For the day-ahead and intraday market timeframes according to the CACM Regulation (Article 68(8)), Congestion Income will be collected by Central Counter Parties or Shipping Agents (in case of implicit allocation) or by allocation platforms (in case of explicit allocation where applicable).

After the collection by the above-mentioned entities, based on the rules described in the CID Methodology, the Congestion Income is assigned to each Bidding Zone border and then, it is distributed to the TSOs on each side of a Bidding Zone border or, via the relevant TSOs, to third party asset owners.

The Commercial Flow is introduced in order to calculate the Congestion Income per Bidding Zone border. “Commercial Flow” means the flow over a Bidding Zone border resulting from single day-ahead coupling or single intraday coupling where it is distinguished as follows:

- i. for CCRs applying the FB approach it is the additional aggregated flow (AAF) and if applicable the external flow as specified in Article 3 of CID methodology; and
- ii. For CCRs applying coordinated NTC approach it means the allocated capacities on the bidding zone border.

In relation to CNTC, the Scheduled Flow shall be equal to the allocated capacities (taking into account all allocation constraints). If price differences arise, due to exhausted bilateral Available Transmission Capacity (ATC), the Scheduled Exchanges will be equal to the ATC (as the ATC is fully used). If another allocation constraint is limiting exchanges over a Bidding Zone Border (e.g. ramping constraints of an HVDC interconnector), then a price difference may arise even if not all available capacity is used. However, in such case the Scheduled Exchanges shall be equal to the allocated capacity on the Bidding Zone Border.

In relation to Flow Based: Congestion Income arises when there is a price difference between the different hubs applying a flow based approach. If there is a price difference, this means that at least one Critical Branch (or the intuitiveness constraint) is limiting exchanges. The congestion income resulting from the congestion is then assigned per Bidding Zone Border. The Congestion Income Distribution uses the AAF to allocate congestion income to each Bidding Zone Border

Scheduled Exchanges, which equal the allocated capacities, are therefore relevant for the calculation of Congestion Income under the CNTC Approach.

5. Scheduled Exchange Calculator

5.1 Calculation process

According to Article 8(2g) of the CACM Regulation, the TSOs shall, where required, establish a Scheduled Exchange Calculator (SEC) for calculating and publishing Scheduled Exchanges on borders between Bidding Zones.

As described above, currently only the former CWE Region has a regionally installed scheduled exchanges calculation process. For other TSOs, the Market coupling algorithm, more precisely the PCR system, is currently fulfilling the function of scheduled flow calculation across Bidding Zones, which are then used as scheduled exchanges.

In line with current developments in order to implement the Single Day Ahead Coupling (SDAC), which will be able to accommodate multiple NEMOs in a bidding zone, the scheduled exchange calculation function will be unified in one system for all TSOs, while adding the additional flow calculations for scheduling areas. By using only one Pan-European SEC, no coordination among different SECs will be necessary in the future. A unified SEC function simplifies the global NEMO-TSO system for SDAC and avoids time-consuming crosschecks across different SEC functions in different regions.

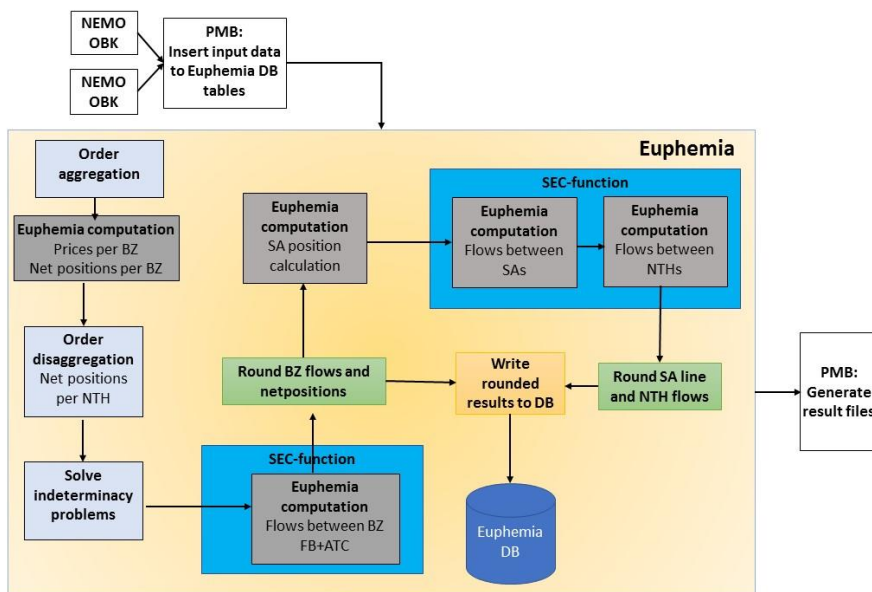

Figure 4: Proposed process by PCR

TSOs will develop governance functionalities for the Scheduled Exchange Calculator in coordination with all NEMOs in line with the SDAC.

5.2 Time Limits for Delivery of Information

In the current Market Coupling Session process, the Calculation step is set to 12 minutes: 10 minutes of Euphemia calculation + 2 minutes for reading input data and writing output data. The target time for this step is 12:22. The Results Sharing step takes 2 minutes and the Preliminary Confirmation of the Results takes 12 minutes. The target time for this step is 12:36. The regular

publication time is 12:42, so the margin between the end of the Preliminary Confirmation and the publication time is 6 minutes.

For the MNA implementation, the Euphemia calculation will be extended by 2 minutes⁴ to host the Scheduling area level flow calculations in the main Calculation run. The whole Calculation step will take 14 minutes. Consequently, the target time for the Results Sharing and the Preliminary Results Confirmation steps will be delayed by 2 minutes (to 12:26 and 12:38 respectively). The margin between the end of the Preliminary Results Confirmation and the regular publication time will be reduced from 6 to 4 minutes. The regular publication time will remain 12:42. As the regular publication time will not be affected, neither will the Final Confirmation times.

Therefore, the methodology requires the delivery of the Scheduled Exchanges so that the day-ahead post-coupling processes can be completed in a timely manner.

6. Calculation Methodology

The Calculation Methodology shall be framed by the following principles:

6.1 General Principles

The calculation methodology for scheduled exchanges shall be based on Net Positions per bidding zone and scheduling area.

Article 6 of the DA SEC Methodology describes a step-wise approach for the calculation of the Scheduled Exchanges per Bidding Zone and Scheduling Area by the Scheduled Exchange Calculator.

1. Bidding zone (BZ) flow calculation;
2. Scheduling area (SA) flow calculation;

The intra scheduling inter NEMO line is out of scope of this document.

⁴ Current assumption of PCR

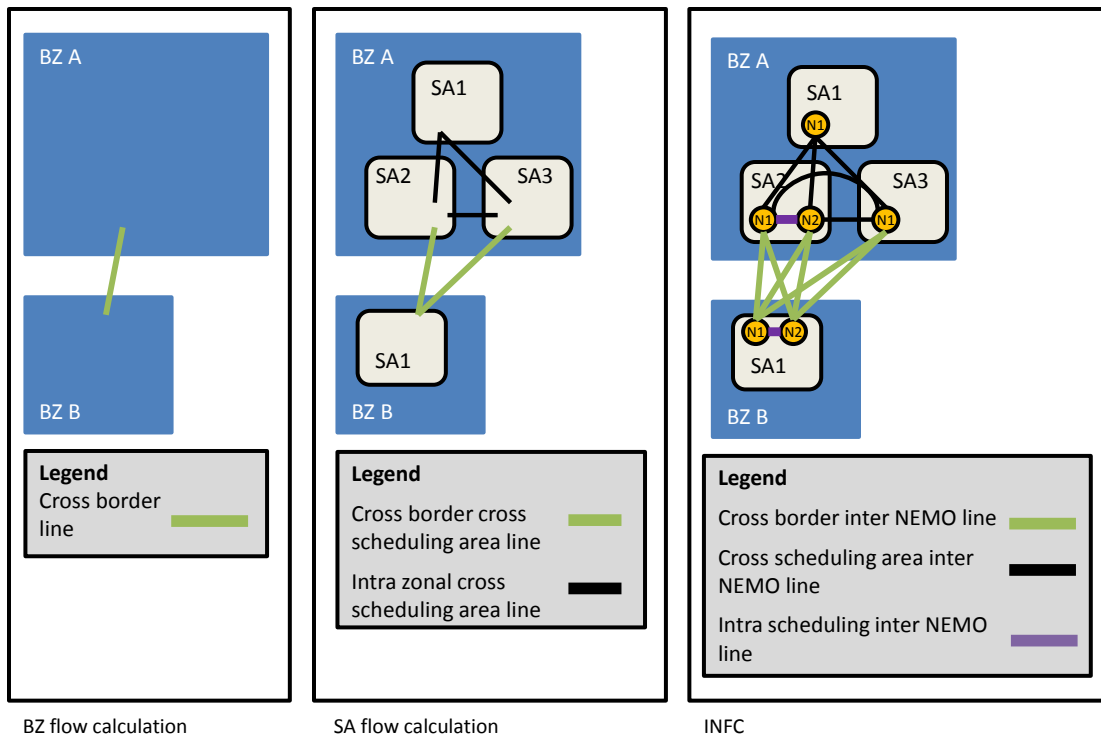

Figure 5: Stepwise approach for the calculation of schedules

Each subsequent step takes as a constraint the output from the step before. The different models each consider their respective topologies.

Overall consistency will be guaranteed among all TSOs and NEMOs across the two levels of flow calculation:

- I. The sum of net positions of the Scheduling Areas in one Bidding Zone must be equal to the net position of the Bidding Zone.

For different Scheduling Areas touching the same BZ border, the sum and direction of the flows on Scheduling Area level shall match the total flow across the BZ border. Each result of the two flow calculation steps would be made available as input for the post-coupling process.

The calculation process described in this explanatory note for the SEC Methodology is aligned with the All NEMOs Algorithm Proposal according to Article 37 of the CACM Regulation.

All constraints described in the DA SEC Methodology shall be respected. Outputs of the DA market coupling operator function shall be respected. Scheduling Restrictions, namely the Intuitiveness Principle (applied to ensure that prices flow from areas of low prices to areas of high prices), have been described in the DA SEC Methodology.

There are situations where there are multiple Scheduling Areas within a Bidding Zone. This can result in situations where there are multiple Scheduling Areas on one side of a border and a single Bidding Zone on the other side of the border. In these situations, the aggregated netted sum of the

Scheduled Exchanges for the multiple Scheduling Areas shall equal the Scheduled Exchanges calculated for the Bidding Zone border.

It is relevant to note that a Net Position and a Scheduled Exchange could be either positive or negative reflecting the import or the export of the electricity transfer.

When considering the CNTC Approach, where a price difference exists between two bidding zones either the available capacity has been fully used or another allocation constraint (e.g. ramping constraint) was active. Hence, if there is a price difference between two bidding zones, within a CCR applying CNTC, the Scheduled Exchange between these two bidding zones shall be equal to the Scheduled Flows between these two bidding zones.

Based on bidding zone net positions, or in case of indeterminacies⁵, several routes could be possible. The optimisation of the Scheduled Exchanges shall therefore aim to minimise the Scheduled Exchanges between the involved bidding zones. For this minimisation, the Scheduled Exchanges between involved bidding zones shall be used as a set of variables to minimise the target function following:

Equation 1

$$\min \left(\sum lc_{i,h} \varphi_{i,h} + \sum qc_{i,h} \varphi_{i,h}^2 \right)$$

With:

- $lc_{i,h}$ = linear cost associated to line i for period h
- $qc_{i,h}$ = quadratic cost associated to line i for period h
- $\varphi_{i,h}$ = flow on line i for period h

The general optimisation function described above allows for the definition of cost coefficients to obtain a certain objective. The costs coefficients (both linear and quadratic) associated to each bidding zone border are provided as an input by TSOs and NEMOs. The cost coefficients are determined in such a way that following objectives are met:

- Uniqueness by introducing a quadratic cost coefficient. When several routes exist with the same length (i.e. an equal number of interconnectors to cross in between) the flow is split equally between these routes: no prioritization between routes with same length if the same quadratic cost coefficient is used.
- Shortest path rule to avoid loops and to ensure a minimization of transits between regions by setting of the linear cost coefficient

⁵ In case there is no congestion between two or more bidding zones applying a CNTC approach (i.e. no allocation constraint was active and the bidding zone prices are equal), then multiple routes are available.

- Prioritization rule to prioritise the use of certain interconnectors by setting a higher, or lower, linear cost coefficient on certain interconnectors.

The cost coefficients are determined in such a way that the general behaviour of the optimisation is balanced and respect the objectives. Hence, the ratio between the different cost coefficients on each bidding zone border is more important than the exact value.

The current cost coefficients applied in the DA MC algorithm (MRC) are the result of a common NEMO-TSO work. When a change in the market topology is introduced (i.e. the addition of a new bidding zone border), then a common task force will evaluate and determine the cost coefficients to be used for the calculation of the exchanges. These cost coefficients are determined such that the objectives described above are met and such that they do not interfere with previous implemented rules. For example, a previously agreed prioritization path shall not be impacted by the creation of a new bidding zone border. The assessment is done based on expert knowledge and specific studies to validate the chosen cost coefficients.

When considering the example below, which illustrates the addition of a new bidding zone border (in red) to the existing market topology, the determination of the linear cost coefficients should be such that the shortest path rule is respected (i.e. no unnecessary transits will happen).

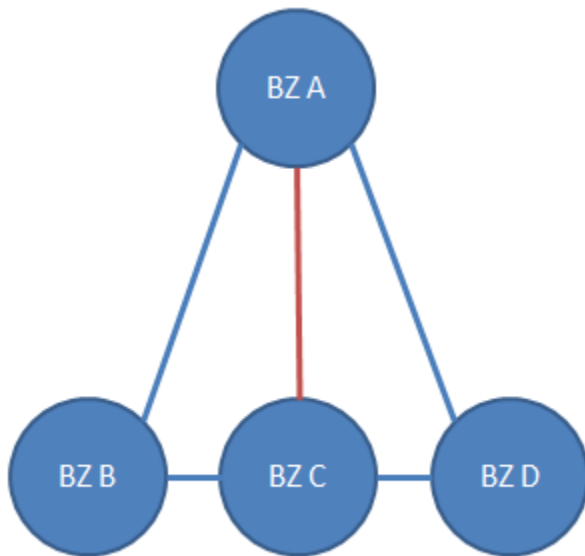

In the before mentioned example, the cost coefficients are given in the table below.

From	To	Linear Cost Coefficient	Quadratic Cost Coefficient
BZ A	BZ B	100	1
BZ A	BZ D	100	1
BZ B	BZ C	100	1
BZ C	BZ D	100	1
BZ A	BZ C	100	1

The calibration of the cost coefficients for the new interconnector BZ C – BZ A should be such that there is no transit of the interconnector from exchanges between BZ B and BZ A and vice versa.

Clearly, if the linear cost coefficient for the bidding zone border CA is put to a very high value (e.g. 1000), then any exchange between BZ C and BZ A will not be scheduled over the new bidding zone border. If the linear cost coefficient is set to 0, then any exchange between BZ B and BZ A can either be scheduled over BZB BA or BZB CA for the same 'cost'. This behaviour is to be avoided. For this case, the optimal solution is to apply the same linear cost coefficient for all bidding zone borders within this region.

The example below illustrated the need for a prioritization path. In this example we consider a situation where there are multiple smaller bidding zones each geographically located close to each other (BZ B to BZ E) and one large bidding zone (BZ A) which spans, again geographically, the before mentioned bidding zones.

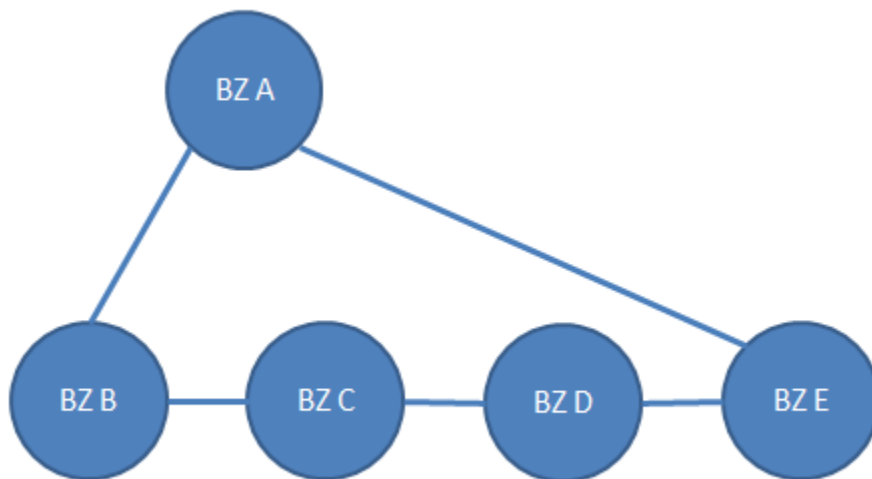

Scheduling an exchange between BZ B and BZ E can be done via BZ A or via BZ C and D. In case of equal cost coefficients, the path via BZ A would be selected. However, a more accurate representation of the flow pattern and physical capacities would schedule the exchange via BZ C and D. In such a case it would make sense to increase the cost coefficients on BZB AE and BZB BA. The increase of the cost coefficients should then be tested so that an exchange between BZ B and BZ A shows the correct behaviour.

From the examples above, it is clear that setting cost coefficients on bidding zone borders is an exercise in finding the right balance between the objectives defined for the market topology.

Furthermore, where relevant, it needs to be ensured that Schedules Exchanges are defined from low price to high price areas. Therefore, an intuitiveness scheduling restriction between bidding zones is applied. The intuitiveness scheduling restriction between bidding zone A and bidding zone B is described as follows:

Equation 2

$$(Price_{BZ B} - Price_{BZ A}) * Bilateral Exchange_{A \rightarrow B} \geq 0$$

6.2 Flow calculation between Bidding Zones (BZ)

Actual methodology applied by Euphemia foresees:

- *Flow calculation between Bidding Zones connected by ATC lines*
Given bidding zones net position, several routes could be possible. In order to define a unique solution, flows calculation is based on a minimization of the costs associated to ATC lines.

Formula to calculate flows is the following:

$$\min \left(\sum lc_{i,h} \varphi_{i,h} + \sum qc_{i,h} \varphi_{i,h}^2 \right)$$

With:

- $lc_{i,h}$ = linear cost associated to line i for period h
- $qc_{i,h}$ = quadratic cost associated to line i for period h
- $\varphi_{i,h}$ = flow on line i for period h

As an example:

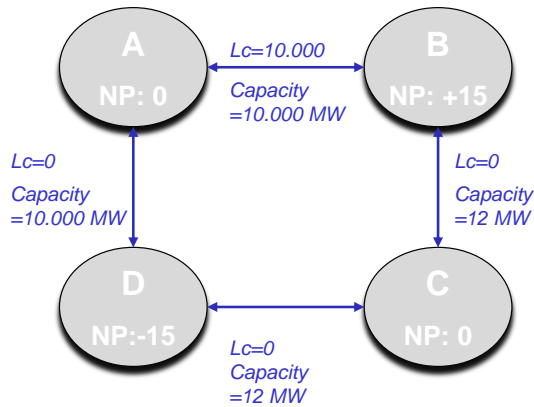

Being NP the net position of Bidding Zones A, B, C and D, the flows will be the following:

- $\varphi_{B \rightarrow C} = 12 \text{ MWh}$
- $\varphi_{C \rightarrow D} = 12 \text{ MWh}$
- $\varphi_{B \rightarrow A} = 3 \text{ MWh}$
- $\varphi_{A \rightarrow D} = 3 \text{ MWh}$

- *Flow calculation between Bidding Zones belonging to a flow based (FB) grid*

Flow based constraints allow TSOs to reflect network constraint by providing a Power Transfer Distribution Factor (PTDF) matrix and constraining their usage. Note that the flow based constraints do not naturally result in (commercial) bilateral exchanges. Instead to retrieve them, Euphemia considers a bilateral topology, for which it shall compute a decomposition of the net positions.

Example:

Consider below simple topology: bidding zones z_1, z_2, z_3 are part of a FB region. Whereas z_4, z_5 and z_6 are coupled via ATC lines. The two regions are linked through ATCs between (z_2, z_4) and (z_3, z_5) . Finally note the indicated topology between the FB region: these are not used for the main welfare optimization phase of Euphemia, but are the dedicated topology for which Euphemia needs to identify bilateral exchanges that decompose the FB net positions.

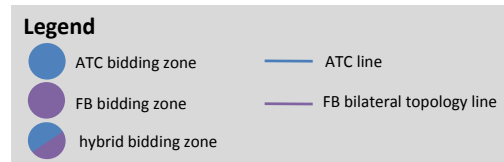
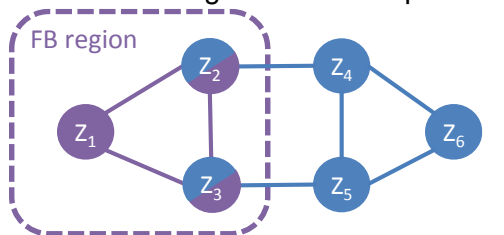

Imagine that Euphemia identifies the optimal solution as:

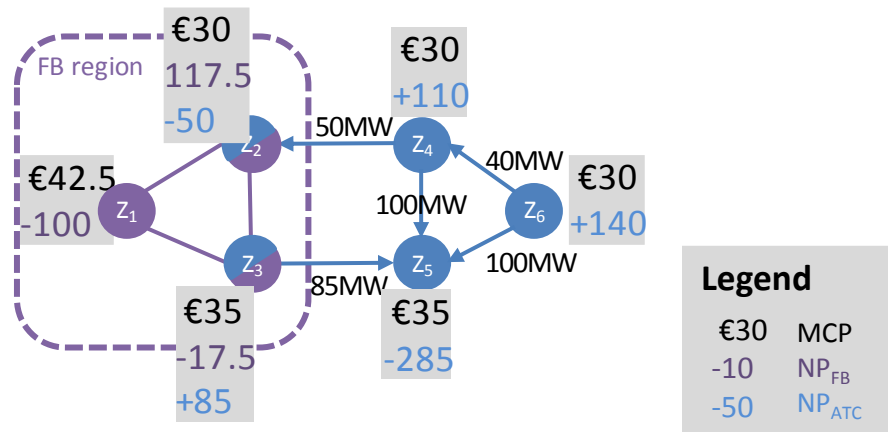

In the example the flows on the ATC lines are already uniquely determined (as there are no uncongested loops). For the flow based flow calculation we consider the FB net positions (the ones indicated in purple): these are the net positions for the FB bidding zones, corrected for the flows already scheduled on ATC lines. The flow calculation model will be an extended version of the ATC one, where $\varphi_{i,h}$ shall now be understood to either correspond to the ATC line flows, or to lines making up the FB bilateral topology, allowing us to combine flow calculation in either ATC or FB regions in a single model.

6.3 Calculation of Scheduled Exchanges per Scheduling Area border

Where the Scheduling Area equals the Bidding Zone, the results from Section 6.2.1 shall apply.

If there is more than one Scheduling Area within a Bidding Zone then:

- The Scheduled Exchange Calculator shall calculate the Scheduled Exchanges between the scheduling areas using the Net Positions per scheduling area.
- For the calculation of Scheduled Exchanges between scheduling areas the same optimisation approach shall be applied as for the Scheduled Exchanges between bidding zones.
- If there are multiple Scheduling Areas on one (or both) side(s) of the Bidding Zone Border, then the Scheduled Exchanges between the Scheduling Areas, over the Bidding Zone Border, shall be attributed to each Scheduling Area Border proportionally to the installed thermal capacity of the interconnections.

Since internal scheduling areas subdivide the bidding zone, and there exist no capacity constraints within the bidding zone, it follows that there exist no capacity constraints between internal scheduling areas. For cross border scheduling areas, capacity constraints can exist. However, the

previous zonal flow calculation step already determined the cross zonal flows, and these flows are imposed as constraints into the scheduling area flow calculation. Furthermore, the cross-border scheduling areas flows will be pro-rated according to installed thermal capacities:

- The installed thermal capacities will only be used to agree a priori how the zonal flow will be split between the different scheduling areas;
- It is important to understand these “installed thermal capacities” do not reflect capacity available to the SDAM

Example:

Imagine a flow from DE/AT → FR of 1200MW is computed by Euphemia. It needs to be split between:

- Amprion → Rte (*example:* installed thermal capacity = 30MW);
- Transnet → Rte; (*example:* installed thermal capacity = 70MW);
- Split:
 - Amprion → Rte: $30/(30+70) * 1200 = 360\text{MW}$;
 - Transnet → Rte: $70/(30+70) * 1200 = 840\text{MW}$;
- Note: we intentionally used silly values for the installed thermal capacities to make clear they are not to be confused with DA cross zonal capacities;

Note: equivalently we could say that 30% shall be scheduled over Amprion → Rte, and 70% over Transnet → Rte;

7. Implementation

The DA SEC Methodology has been aligned with the All NEMOs’ Proposal for the price coupling algorithm, incorporating a common set of requirements for the price coupling algorithm in accordance with Article 37(4) of the CACM Regulation. All TSOs highlight that there is a risk associated with the difference in time frames between the deadline for submission of the DA SEC Methodology and the All NEMOs Proposal for the price coupling algorithm. The List of Information Required from Relevant NEMOs as provided in Article 3 of the DA SEC Methodology is essential for the DA SEC Methodology. This risk has been mitigated by ensuring that the All NEMOs Proposal as submitted to NRAs includes the List of Information Required from Relevant NEMOs as outlined in Article 3 of the DA SEC Methodology.

The DA SEC Methodology is currently implemented by a subset of TSOs as described in Section 1.2 above. Amendments may be required to this DA SEC Methodology based on, but not limited to, the following list:

- capacity calculation methodology developments and obligations in accordance with Article 20 of the CACM Regulation;
- the Multi-NEMO Arrangements in accordance with Article 45 of the CACM Regulation;

- the All NEMOs' Proposal for the price coupling algorithm in accordance with Article 37(5) of the CACM Regulation; and
- developments to the day-ahead market coupling operator function in accordance with Article 7(3) of the CACM Regulation.

Additionally, as per Article 43 of the CACM Regulation no later than two years after the approval by the regulatory authorities of the concerned region of the DA SEC Methodology, TSOs applying Scheduled Exchanges shall review the methodology. All TSOs shall take part in this review.

authorities of the concerned region of the DA Scheduled Exchanges Calculation Methodology, TSOs applying Scheduled Exchanges shall review the methodology. All TSOs shall partake in this review.

Description Flow Calculation between NEMO Trading Hubs (NTHs)

The Flow Calculation between NTHs, also called INFC (for *Inter-NEMO Flow Calculation*), aims at determining the proper quantities to be exchanged between NEMO trading hubs. It is required for:

- Physical shipping as it shall equilibrate with cross-border exchanges
- The determination of cross-clearing exchanges at financial settlement stage

The INFC model takes into account several types of input data:

- The set of NTH net position values, already computed
- The zonal clearing prices, already computed
- The set of scheduling area flow values, already computed
- The topology connecting NTHs together, i.e. the set of inter-NTH lines and their associated properties (cost coefficients), provided as input data

Optimization principle

The INFC aims at determining the optimal flows between NTHs. To do so, it considers a criterion called *financial exposure* between NEMOs (or more precisely between their associated central counterparty clearing houses⁶, or CCPs), which tries to be minimized equally among NEMOs. The exposure minimization approach aims at securing the day-ahead market coupling by limiting the effective financial exchanges between distinct CCPs, in order to prevent the collateral limits to be breached in exceptional cases.

First, the *net exposure* term NE between each pair of CCPs (A, B) is expressed as follows:

$$NE_{A|B} = \sum_{h \in H} \sum_{l=(n_1, n_2) \in L_{A,B}} P_{n_2}^h * flow_{n_1, n_2}^h - P_{n_1}^h * flow_{n_2, n_1}^h$$
$$L_{A,B} = \{l = (n_1, n_2) \in L^d \mid ccp(n_1) = A \wedge ccp(n_2) = B\}$$

Where h is the period of the session, L^d is the set of directed inter-NTH lines, P_n^h is a shorthand for the zonal clearing price applying on NTH n at period h and $flow_{n_1, n_2}^h$ is the flow from NTH n_1 to NTH n_2 . $ccp(n)$ is a function which provides the CCP associated to NTH n .

The net exposure $NE_{A|B}$ of a CCP A with regards to a CCP B expresses the financial risk that B will induce on A . As can be seen, it is netted over all BZs and periods. A net exposure can either be positive or negative. Also, it can be shown that $NE_{A|B} = -NE_{B|A}$ (therefore, as soon as it is non-null, they shall have opposite signs). The sum of all net exposures among all pairs of CCPs shall always be zero (financial balance).

To solve the exposure minimization problem, the INFC is defined in two steps:

- 1: minimize the net exposure using a sum of quadratic terms in order to guarantee an equal treatment of all CCPs
- 2: fix the exposure amounts, and solve a second minimization problem using linear and quadratic cost coefficients to break the indeterminacies and retrieve a consistent solution

Sets and Parameters

⁶ CCPs are financial institutions associated to PXs/NEMOs and responsible for managing the counterparty credit risk related to all exchanges operated in the context of the day-ahead market coupling.

$\overline{flow}_{sa_1,sa_2}$	The flow from scheduling area sa_1 to scheduling area sa_2
NTH	The set of NTHs
CCP	The set of CCPs ($CCP = \{ccp(n) \forall n \in NTH\}$)
\overline{NP}_n	The net position of NTH n , $\forall n \in NTH$
L^d	The set of directed inter-NTH flows
c_l	The linear cost coefficient associated to an inter-NTH line l , $\forall l \in L^d$
q_l	The quadratic cost coefficient associated to an inter-NTH line l , $\forall l \in L^d$

Variables

$flow_{l=(n_1,n_2)}$: the flow from NTH n_1 to NTH n_2 , $\forall l \in L^d$

Optimization Model 1 (exposure minimization)

$\min \sum_{c \in CCP} \sum_{c' \in CCP \setminus \{c\}} (NE_{c c'})^2$		
s. t.		
$\overline{flow}_{sa_1,sa_2} =$	$\sum_{l=(n,n') \in L^d SA(n)=sa_1, SA(n')=sa_2} flow_l$	$\forall z_1, z_2 \in BZ^2$ (1)
$\overline{NP}_n =$	$\sum_{l^-= (n,n') \in L^d} flow_{l^-} - \sum_{l^+ = (n',n) \in L^d} flow_{l^+}$	$\forall n \in NTH$ (2)

Where $SA(n)$ is a function returning the scheduling area associated to NTH n . The first equation ensures that the sum of all inter-NTH flows associated to a scheduling area flow is balanced. The second equation ensures that the sum of flows entering/leaving a NTH is balanced with its related net position.

It is assumed that there can be no inter-NTH flow going into opposite direction than an associated cross-border flow.

As there may be many symmetries or indeterminacies in the first optimization model, a second optimization step is then used to prevent cycles in the flows and to retrieve a more consistent solution using the cost coefficients of the lines.

Optimization Model 2 (indeterminacy management)

$\min \sum_{(n_1, n_2) \in TOP_{NTH}} (c_{n_1, n_2} \cdot flow_{n_1, n_2} + q_{n_1, n_2} \cdot (flow_{n_1, n_2})^2)$			
s.t.			
$\overline{flow}_{sa_1, sa_2} = \sum_{l=(n, n') \in L^d \mid SA(n)=sa_1, SA(n')=sa_2} flow_l$	$\forall z_1, z_2 \in BZ^2$	(3)	
$\overline{NP}_n = \sum_{l^-(n, n') \in L^d} flow_{l^-} - \sum_{l^+(n', n) \in L^d} flow_{l^+}$	$\forall n \in NTH$	(4)	
$NE_{c c'} = \overline{NE}_{c c'}$		$\forall c \in CCP, c' \in CCP \setminus \{c\}$	(5)

Where $\overline{NE}_{c|c'}$ is the net exposure value obtained after solving the first optimization presented above. In this model, we consequently fix the net exposure values, but flows may be adjusted in order to minimize according to the line coefficients. The flow consistency constraints are identical to the first model.

1 Contents

1. Purpose of the document	30
2. Glossary	30
3. Euphemia MNA coupling process	32
3.1 Euphemia perspective on sequence of the coupling calculation process ...	32
3.2 Functioning of the order aggregation	33
3.3 Zonal calculation	35
3.4 Functioning of the order de-aggregation	35
3.5 Functioning and coherence of the 3 flow calculation steps.....	35
3.5.1 Flow calculation between Bidding Zones (BZ).....	37
3.5.2 Flow calculation between Scheduling Areas (SA)	40
3.5.3 SEC Backup calculation process (degraded mode)	44
3.5.4 Rounding solution	50
3.6 Solution validation.....	55
3.7 Change Control.....	55
4. Procedures	57
4.1 Normal Procedures	57
4.2 SEC Degraded Mode.....	58
4.3 Decoupling Procedures.....	58
5 PMB requirements	60
5.1 Shared Configuration file changes	61
5.2 CZC submission	62
5.2.1 Cross-check modes	62
5.2.2 Network data validation GUI	64
5.3 Order data submission.....	64
5.4 Interface changes towards algorithm.....	65
5.4.1 Order Data.....	65
5.4.2 Results.....	65
5.4.3 Tie break rules between blocks.....	65
5.5 Show Results GUI.....	65
5.6 Results document	65
5.7 Identification codes of BZ, SA, NH and Tie lines	65
5.8 Changes in PBM due to decoupling	66

1. Purpose of the document

This document describes the functional requirements for the coupling part of the Single Day Ahead Coupling capable to facilitate multiple NEMOs per Bidding Zone as required by CACM, also called MNA (Multi-Nemo Arrangement). The current PCR market coupling solution including PMB and Euphemia, and its operational procedures is facilitating only one NEMO per Bidding Zone. Therefore, a change request will have to be issued, and implementation to PMB and Euphemia shall start as soon as this document and the requirements have been agreed by all NEMOs, all TSOs and NRAs.

This document contains the current working assumption for the requirements. The confirmation that these requirements are indeed algorithmically feasible, can only be given after the prototype of the algorithm is built and tested.

This document does not cover the functional requirements for the changes in the pre-coupling or the post-coupling. These changes are discussed outside the scope of PCR.

2. Glossary

In the following text a series of concepts and acronyms are being used. This section contains a reference to all of them.

Item	Description
CCP	'Central counter party' means the entity or entities with the task of entering into contracts with market participants, by novation of the contracts resulting from the matching process, and of organising the transfer of net positions resulting from capacity allocation with other central counter parties or shipping agents
DB	Database
Euphemia	The algorithm used in single day-ahead coupling for simultaneously matching orders and allocating cross-zonal capacities
MTU	Market Time Unit
NP	Net Position
BZ	Bidding Zone
NTH	NEMO trading hub – combination of NEMO, active in a scheduling area, within a bidding zone
OBK	Order book
SEC	Scheduled Exchange Calculation (cf. All TSOs' proposal for a Methodology for Calculating Scheduled Exchanges resulting from single day-ahead coupling in accordance with Article 43 of the Commission Regulation (EU) 2015/1222 of 24 July 2015 establishing a guideline on capacity allocation and congestion management)
SA	Scheduling Area
SCF	Shared configuration file, used for configuring various aspects of the PMB setup

3. Euphemia MNA coupling process

3.1 Euphemia perspective on sequence of the coupling calculation process

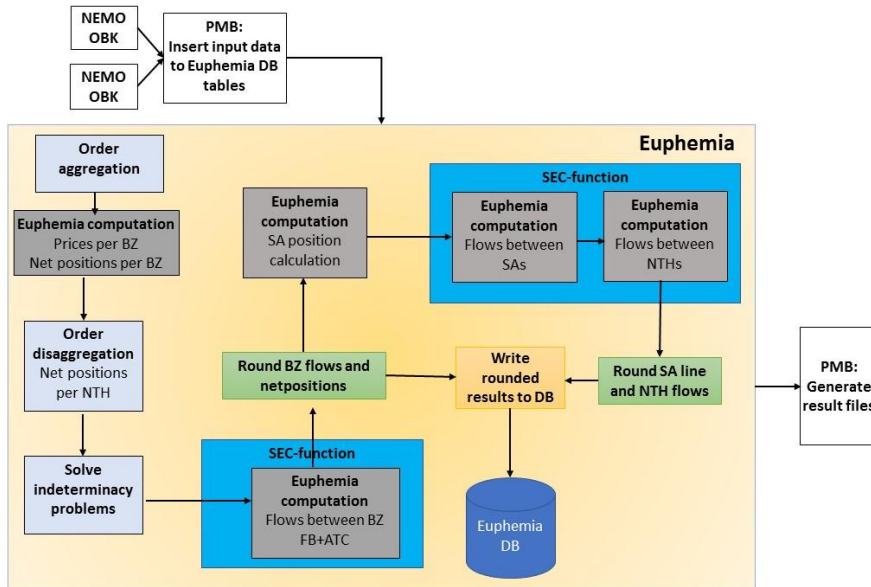

Figure 6: Calculation process

General assumptions:

- Minimum and maximum prices as well as precision (number of decimals) of price and precision (number of decimals) of net position are defined at bidding zone level.
- Ramping limits are applied at bidding zone level.
- There exist no allocation constraints between the different NTHs belonging to the same bidding zone. Therefore, we can aggregate the different NTH OBKs without risk of violating allocation constraints.

Calculation steps:

1. **Upload orderbooks:** Orderbooks are received from different NEMOs in each bidding zone and for each Scheduling Area when applicable. PMB writes orderbook data in Euphemia database input tables. Euphemia calculations can start.
2. **Orderbook aggregation:** Orderbooks are aggregated on bidding zone level.
3. **Price/Volume computation:** Prices and volumes per bidding zone are computed.
4. **Order disaggregation:** Results are calculated on Nemo Hub level. Indeterminacy problems are solved. NEMO Hub level exact results are written in database.
5. **Indeterminacy problems** are solved.
6. **Flows between bidding zones** are calculated, in both flow based and ATC network. As in previous versions of Euphemia, bi-directional flows on bidding zone lines are avoided.

7. **Rounding:** BZ flows and BZ net positions are rounded. Rounded results are written to database.
8. **SA positions** are calculated.
9. **Flows between SAs** are calculated. In this flow calculation, flows between bidding zones are fixed. Thermal capacity constraints for scheduling area lines between different bidding zones are constraining the calculation. They distribute the bidding zone flows among the corresponding scheduling area lines proportionally to their thermal capacities. Where there is freedom to set the scheduling area flows, this is resolved through an objective function that considers minimization of a cost function that weighs flows with appropriate linear and quadratic cost coefficients.

Aggregated value of flows for the scheduling area lines that represent the same bidding zone line corresponds to the values from the flow problem on bidding zone level.

Cross border scheduling area flows shall follow the same direction as the corresponding cross border zonal flows.

10. **Flows between NTHs** are calculated. Earlier calculated flows between bidding zones and scheduling areas are kept fixed during this flow calculation.

NEMO flows belonging to scheduling area flows are not allowed in different directions.

NEMO flows belonging to cross zonal flows are not allowed in different directions (which should be a direct consequence from the former and the fact that scheduling area flows are also required to follow the cross zonal flow direction)

NEMO flows within a bidding zone are not allowed in different directions (i.e. no bi-directional flows are allowed).

Aggregated value of flows for the NEMO lines that represent the same scheduling area line correspond to the values from the flow problem on scheduling area level.

11. SA line and NTH flow results are rounded and rounded results written to DB

3.2 Functioning of the order aggregation

Input data from NEMOs will be collected on NEMO trading hub level, whereas matching algorithm need to handle main computation steps (to calculate prices, NPs and flows) on bidding zone level. Aggregation of NEMOs input data to bidding zone level is performed in the beginning of the order aggregation. Thereby EUPHEMIA would consider the existing bidding zone topology without NEMO trading hubs, and without scheduling areas, whereas the order books at input would reflect the orders of all underlying NEMOs with NEMO trading hubs.

With introduction of MNA support anonymization approach of different order types remains unchanged. MCO function will collect all the order books data already anonymised at the same level data is provided today, i.e. order book data are released from any reference to market

participant before handed over to MCO function. Such approach is fully in compliance with CACM Article 47(6).

Curves Aggregation

NTH hourly order curves⁷ need to be aggregated into two single hourly order curves, one sale and one purchase curve per each bidding zone. The type of the resulting aggregated curve shall be:

- STEPWISE if all NEMO curves of the corresponding bidding zone are of STEPWISE type
- PIECEWISE if all NEMO curves of the corresponding bidding zone are of PIECEWISE type
- HYBRID otherwise

Block Orders' Aggregation

In fact blocks orders are not aggregated literally. Block orders of NEMOs that belong to a bidding zone are just combined; including linked block families, flexibly hourly orders and exclusive groups. Blocks IDs uniqueness within one bidding zone will be assured by PMB, which will generate unique internal block IDs per session.

Furthermore each block will also be associated with a hash: this can then be used for settling ties between identical blocks submitted by different NEMOs.

Complex Orders' Aggregation

In fact complex orders are not aggregated literally. Complex orders of NEMOs belonging to a bidding zone are just combined, similarly like in case of block orders. Complex Orders' IDs uniqueness within one bidding zone would be assured by PMB, which will generate internal unique complex order IDs per session.

Merit Orders

It is not expected that multiple NEMOs use merit orders, hence no support will be provided for such case. If some NEMOs active in areas with multiple NEMOs would indicate a desire to start using merit orders, further work will be required to describe a solution to support them.

Aggregation of order books would be necessary for those bidding zones, where the MNA setup applies. For bidding zones with a single NEMO, the input curves and aggregated curves will be identical. The aggregation pre-processing will be performed at EUPHEMIA, so PMB will provide input data to EUPHEMIA at NTH level. Data model of the EUPHEMIA needs to be enhanced to accommodate NEMO notions accordingly, mainly:

- Distinction of bidding zone, scheduling area and NEMO trading hub relations
- Specification of NEMO trading hubs and scheduling area topology
- Storing data of NEMO input order books
- Storing data of order books aggregated to bidding zone level constructed within aggregation step⁸

⁷ The "hourly" curves may be read as MTU curves, in the sense that Euphemia can process curves received per MTU. For historical reasons in PCR we tend to refer to these as hourly curves.

⁸ By default there would be no need for the resulting aggregated curves per bidding zone to be stored explicitly in the database. However, for debug purposes, the aggregated curves could be written (as output) into dedicated data structures.

3.3 Zonal calculation

After the aggregation of NEMO OBKs, the algorithm will follow its normal overall welfare maximisation. Note that in this section we are calculating the prices, energies and flows for all existing bidding zones.

3.4 Functioning of the order de-aggregation

The de-aggregation module shall have the following responsibilities:

1. Solve the volume indeterminacy problems at NTH level
2. De-aggregate, i.e. divide the traded volumes to NTHs
3. Validate de-aggregation results through extension of the Euphemia output checks
4. Compute NTH results

After Euphemia finds a feasible solution to the aggregated zonal problem, it then needs to split into results applicable to the NEMO trading hub level.

When splitting results down to the NTH level, indeterminate cases need to be resolved. To this end the volume indeterminacy problems that are solved at the zonal level today, need to be applied to the NTH level under the MNA.

Euphemia implements block order tie rules to arbitrate between identical blocks, when only some, but not all can be accepted. With the introduction of the MNA we now also need to arbitrate between identical blocks, which were submitted by different NTHs.

3.5 Functioning and coherence of the 3 flow calculation steps

In the following three sections we will describe the 3 flow calculation sub-problems:

3. Bidding zone (BZ) flow calculation;
4. Scheduling area (SA) flow calculation;
5. Inter NEMO trading hub (NTH) flow calculation

The different levels are illustrated below:

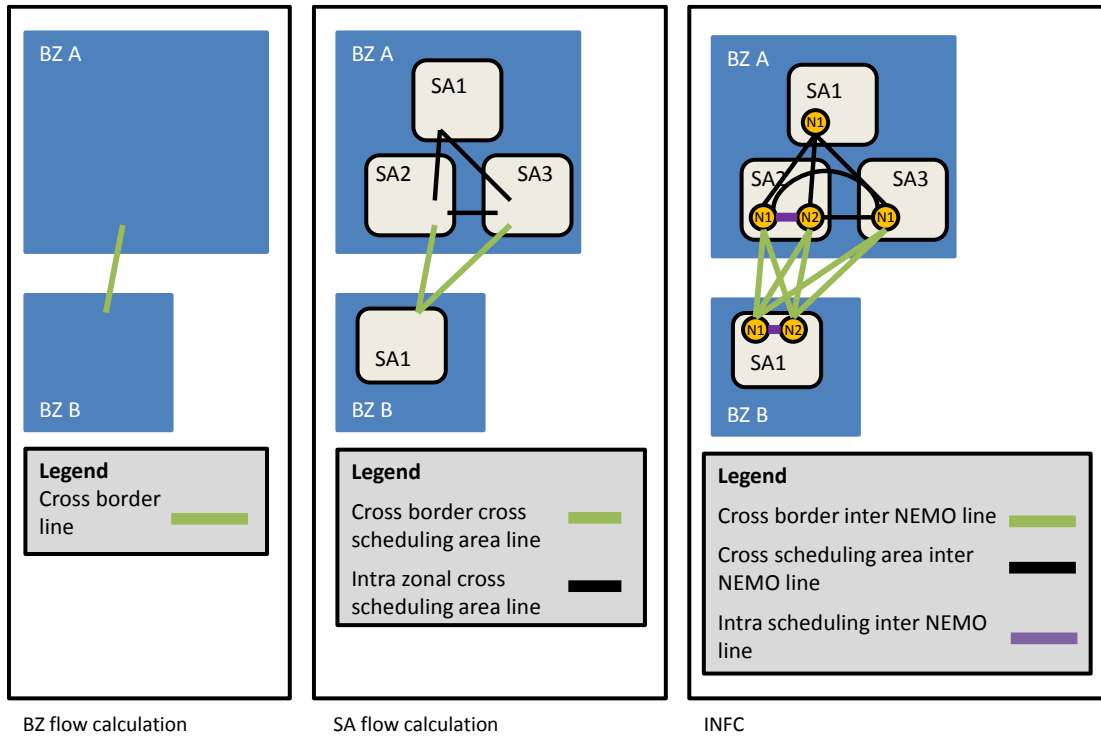

Each subsequent step takes as a constraint the output from the step before. The different models each consider their respective topologies. We introduce some notational conventions to describe the topologies. The notation introduced here has a direct correspondence to the DB interface described in section **Shared Configuration file changes**.

The algorithm model assumes that each NEMO trading hub will belong to exactly 1 scheduling area, and each scheduling area belongs to exactly 1 bidding zone. Consequently each NEMO trading hub can be uniquely associated to a bidding zone. In the opposite direction the relation is that each bidding zone has at least 1 scheduling area, and each scheduling area has at least 1 NEMO. This is illustrated in below figure.



Figure 7 Relations between bidding zone and scheduling area, and scheduling area and NEMO trading hub

We define the following sets and indices as part of our notational convention:

- BZ the set of all bidding zones, i.e. $bz \in BZ$ describes all bidding zones;
- SA the set of all scheduling areas, i.e. $sa \in SA$ describes all scheduling areas;
- NH the set of all NEMO trading hubs, i.e. $nh \in NH$ describes all NEMO trading hubs;

We introduce some abusive notation to infer the relevant parents (unique elements) or children (sets), i.e.

An element nh of the set NH is contained in scheduling area $nh.sa$ which belongs to the SA set;
 An element sa of the set SA is contained in bidding zone $sa.bz$ which belongs to BZ set;
 (And it follows that nh is in bidding zone $nh.sa.bz$)

An element bz of the set BZ contains scheduling areas bz.SA;
 An element sa of the set SA contains NEMO trading hubs sa.NH

The different topologies can now be described within the relevant Cartesian products:

TOP_{bz}: the zonal topology, with $(i, j) \in TOP_z \subset BZ \times BZ, i \neq j$

TOP_{SA}: the scheduling area topology, with $(i, j) \in TOP_{SA} \subset SA \times SA, i \neq j$

TOP_{NH}: the NEMO trading hub topology, with $(i, j) \in TOP_{NH} \subset NH \times NH, i \neq j$

Finally in order to allow the higher level flow calculation results to be imposed as constraints to the lower level ones, the different topologies should be consistent.

Assumptions

1. For each bidding zone line there should be at least one underlying scheduling area line;
2. For each scheduling area line there should be at least one underlying NEMO trading hub line;

Or more formally:

$\forall (bz_i, bz_j) \in TOP_{bz} : \exists (sa_1, sa_2) \in TOP_{SA} \mid sa_1.bz = bz_i \text{ AND } sa_2.bz = bz_j$, and

$\forall (sa_i, sa_j) \in TOP_{sa} : \exists (nh_1, nh_2) \in TOP_{NH} \mid nh_1.sa = sa_i \text{ AND } nh_2.sa = sa_j$

3. NEMO lines are defined in the same direction as the corresponding cross-zonal line
4. In each bidding zone, the NEMO hub topology is made of a single connected component (i.e. each NEMO hub is connected to each other NEMO hub via at least one route)

3.5.1 Flow calculation between Bidding Zones (BZ)

According art.49 of CACM, each scheduled exchange calculator shall calculate scheduled exchanges between Bidding Zones for each market time unit in accordance with the methodology established by TSOs in Article 43.

Actual methodology applied by Euphemia foresees:

- *Flow calculation between Bidding Zones connected by ATC lines*
 Given bidding zones net position, several routes could be possible. In order to define a unique solution, flows calculation is based on a minimization of the costs associated to ATC lines.
 Formula to calculate flows is the following:

$$\min \left(\sum lc_{i,h} \varphi_{i,h} + \sum qc_{i,h} \varphi_{i,h}^2 \right)$$

With:

- $lc_{i,h}$ = linear cost associated to line i for period h
- $qc_{i,h}$ = quadratic cost associated to line i for period h
- $\varphi_{i,h}$ = flow on line i for period h

An example:

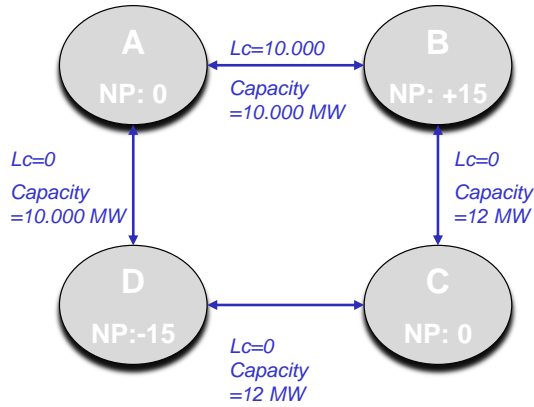

Being NP the net position of Bidding Zone A, B, C and D, the flows will be the following:

- $\varphi_{B \rightarrow C} = 12 \text{ MWh}$
- $\varphi_{C \rightarrow D} = 12 \text{ MWh}$
- $\varphi_{B \rightarrow A} = 3 \text{ MWh}$
- $\varphi_{A \rightarrow D} = 3 \text{ MWh}$

- *Flow calculation between Bidding Zones belonging to a flow based (FB) grid*
Flow based constraints allow TSOs to reflect network constraint by providing a Power Transfer Distribution Factor (PTDF) matrix and constraining their usage:

$$\sum PTDF_{z,h,i} NP_{z,h} \leq RAM_{h,i}$$

With:

- $PTDF_{z,i,h}$ = Impact of an injection of 1 MWh in the Bidding Zone Z on period h on the critical branch or critical outage i
- $NP_{z,h}^{FB}$ Net position of Bidding Zone z in the period h for the FB region. The zones total net position is $NP_{z,h}^{FB}$ + all outgoing ATC line flows – all incoming ATC line flows
- $RAM_{i,h}$ = remaining available margin on critical branch or critical outage i for period h

Parameters $PTDF_{z,i,h}$, $NP_{z,h}^{FB}$ and $RAM_{i,h}$ are not mandatory.

Note that the flow based constraints do not naturally result in (commercial) bilateral exchanges. Instead to retrieve them, Euphemia considers a bilateral topology, for which it shall compute a decomposition of the net positions.

Example

Consider below simple topology: bidding zones z_1, z_2, z_3 are part of a FB region. Whereas z_4, z_5 and z_6 are coupled via ATC lines. The two regions are linked through ATCs between (z_2, z_4) and (z_3, z_5) . Finally note the indicated topology between the FB region: these are not used for the main welfare optimization phase of Euphemia, but are the dedicated topology for which Euphemia needs to identify bilateral exchanges that decompose the FB net positions.

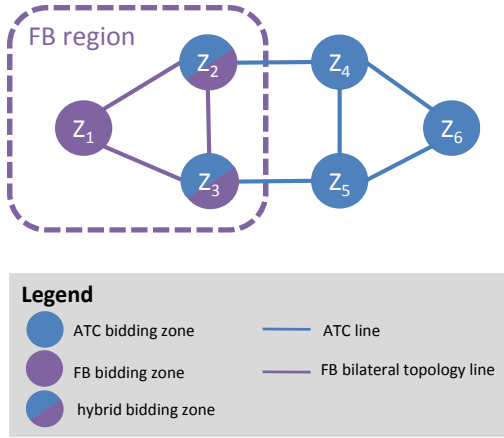

Imagine that Euphemia identifies the optimal solution as:

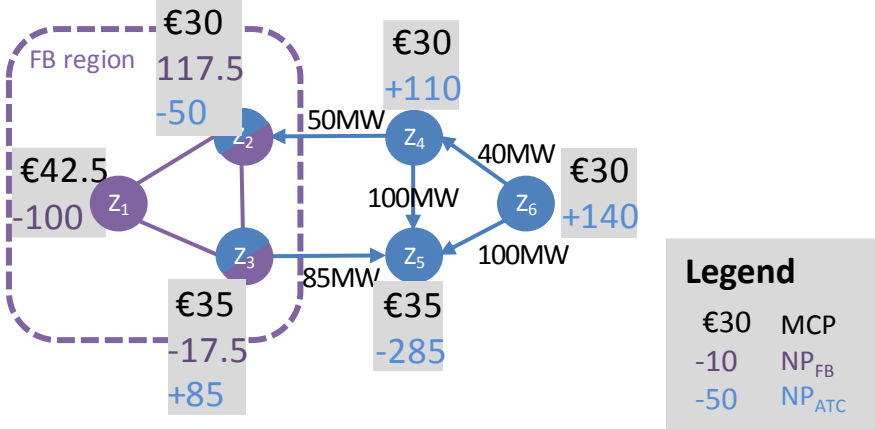

In the example the flows on the ATC lines are already uniquely determined (as there are no uncongested loops). For the flow based flow calculation we consider the FB net positions (the ones indicated in purple): these are the net positions for the FB bidding zones, corrected for the flows already scheduled on ATC lines.

Assuming that TSOs didn't define any values for parameters $PTDF_{z,i,h}$, $NP_{z,h}^{FB}$ and $RAM_{i,h}$, flow calculation model will be an extended version of the ATC one:

$$\min \left(\sum lc_{i,h} \varphi_{i,h} + \sum qc_{i,h} \varphi_{i,h}^2 \right)$$

With:

- $lc_{i,h}$ = linear cost associated to line i for period h
- $qc_{i,h}$ = quadratic cost associated to line i for period h
- $\varphi_{i,h}$ = flow on line i for period h

s.t.

$$NP_z^{FB} = \sum_{i \in FB \text{ top } i. \text{from} = z} \varphi_i - \sum_{i \in FB \text{ top } i. \text{to} = z} \varphi_i$$

Where $\varphi_{i,h}$ shall now be understood to either correspond to the ATC line flows, or to lines making up the FB bilateral topology, allowing us to combine flow calculation in either ATC or FB regions in a single model.

Each line in the FB topology can be individually set to either allow or not allow adverse flows. If a line in the topology does not allow adverse flows, there will be infinite capacity from the lower priced market to the higher priced market, but 0 in the adverse direction. If both prices are equal, there will be infinite capacity in both directions. If the line does allow adverse flows, there will be infinite capacity in both directions, regardless of the prices.

3.5.2 Flow calculation between Scheduling Areas (SA)

Bidding zones by definition do not impose internal capacity constraints, and therefore are at the core of the capacity allocation. To support the post coupling processes, additional flows will be calculated by the algorithm as well. In this section the flows between the “scheduling areas” are detailed.

Scheduling areas correspond to the delivery areas within each bidding zone. Typically there is only a single TSO for each bidding zone, so the relation is 1:1. The exception is the DE/AT/LU⁹ bidding zone, where energy can be delivered to more than 1 scheduling areas.

As illustrated in Figure 8, there are 4 scheduling areas in Germany plus APG for Austria, which gives 5 scheduling areas for the DE/AT/LU bidding zone. Nonetheless the modelling of the scheduling area allows one to configure any number of scheduling areas per bidding zone.

Limitations

Although the model may be sufficiently generic to allow scheduling areas in each bidding zone, only the bidding zone that includes Germany (today the DE/AT/LU bidding zone) may contain scheduling areas. Any request for scheduling areas outside of Germany will be considered a change request.

⁹ Upon implementation of capacity allocation on the DE/LU-AT border in October 2018, this bidding zone will be split into DE/LU with 4 scheduling areas and AT with 1 scheduling area.



Figure 8 German TSOs which correspond to DE scheduling areas. The anticipated scope of the DE/AT/LU bidding zone also includes the APG scheduling area.

The scheduling areas are configured via the Shared Configuration File. Each bidding zone will have at least a single scheduling area associated. For the bidding zone that includes Germany more than 1 scheduling areas can be associated.

Apart from the scheduling areas, there shall be a scheduling area topology that needs to be defined, as illustrated in the figure below:

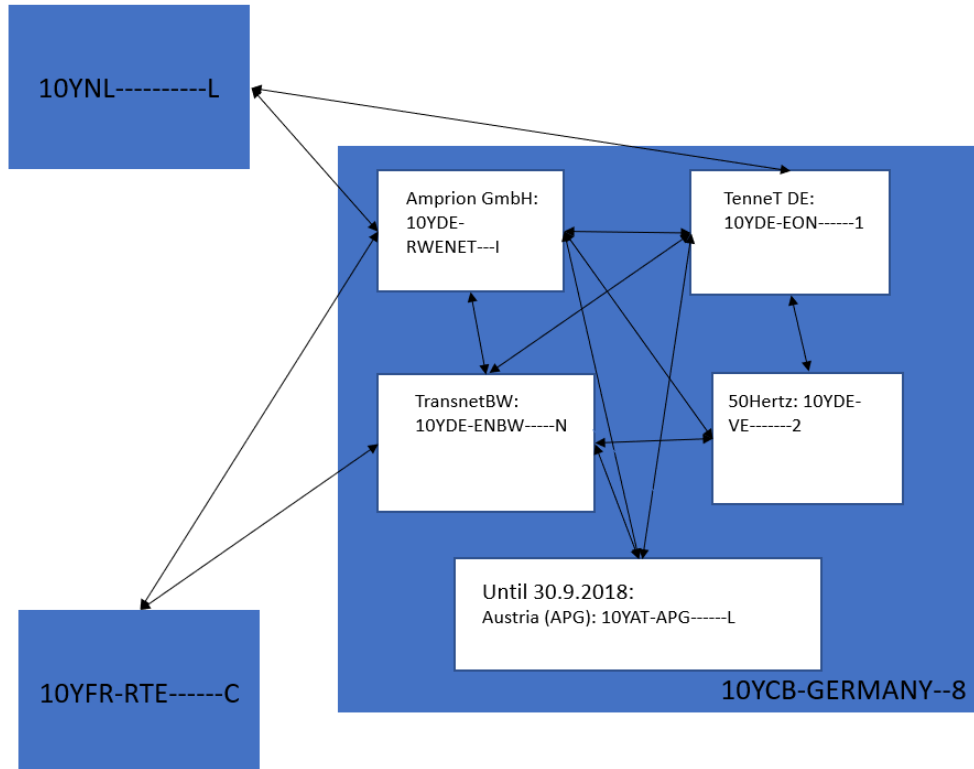

Figure 9 Schematic description of all the scheduling areas and the scheduling area lines, for which the CWE TSOs have requested results.

Since internal scheduling areas subdivide the bidding zone, and there exist no capacity constraints within the bidding zone, it follows that there exist no capacity constraints between internal scheduling areas. For cross border scheduling areas, capacity constraints can exist. However the previous zonal flow calculation step already determined the cross zonal flows, and these flows are imposed as constraints into the scheduling area flow calculation. Furthermore, the cross-border scheduling areas flows will be pro-rated according to installed thermal capacities:

- The installed thermal capacities will only be used to agree a priori how the zonal flow will be split between the different scheduling areas;
- It is important to understand these “installed thermal capacities” do not reflect capacity available to the System Day Ahead Market.
- *Example:* imagine a flow from DE/AT → FR of 1200MW is computed by Euphemia. It needs to be split between:
 - Amprion → Rte (*example:* installed thermal capacity = 30MW);
 - Transnet → Rte; (*example:* installed thermal capacity = 70MW);
 - Split:
 - Amprion → Rte: $30/(30+70) * 1200 = 360\text{MW}$;
 - Transnet → Rte: $70/(30+70) * 1200 = 840\text{MW}$;
 - Note: we intentionally used silly values for the installed thermal capacities to make clear they are not to be confused with DA cross zonal capacities;
 - Note: equivalently we could say that 30% shall be scheduled over Amprion → Rte, and 70% over Transnet → Rte;

For Euphemia to establish the relevant ratios (percentage), it needs to receive the thermal capacities as an input.

Parameters

$\overline{flow}_{z1,z2}$	the flow between zones z1 and z2, $\forall (z_1, z_2) \in TOP_z$
\overline{NP}_{sa}	the net position of scheduling area sa
$c_{sa1,sa2}$	the linear cost coefficient between scheduling areas sa1 and sa2, $\forall (sa_1, sa_2) \in TOP_{SA}$
$q_{sa1,sa2}$	the quadratic cost coefficient between scheduling areas sa1 and sa2, $\forall (sa_1, sa_2) \in TOP_{SA}$
$TC_{sa1,sa2}$	The thermal capacity installed between sa1 and sa2 $\forall (sa_1, sa_2) \in TOP_{SA} \cap (z_1.SA \times z_2.SA)$, $\forall (z_1, z_2) \in TOP_z$ (there are thermal capacities only for scheduling area lines that cross a bidding zone border)

Variables

$flow_{sa1,sa2}$: the flow between scheduling areas sa1 and sa2, $\forall (sa_1, sa_2) \in TOP_{SA}$

Model

$\min \sum_{(sa_1, sa_2) \in TOP_{SA}} (c_{sa_1, sa_2} \cdot flow_{sa_1, sa_2} + q_{sa_1, sa_2} \cdot (flow_{sa_1, sa_2})^2)$		
s.t.		
$flow_{sa_1, sa_2} = \frac{TC_{sa1,sa2}}{\sum_{\substack{(i,j) \in \\ TOP_{SA} i.z=z_1 \& j.z=z_2}} TC_{sa_1,sa_2}} \cdot \overline{flow}_{z1,z2}$	$\forall (sa_1, sa_2) \in TOP_{SA} \cap (z_1.SA \times z_2.SA)$, $\forall (z_1, z_2) \in TOP_z$	(6)
$NP_{sa} = \sum_{(sa_1, sa_2) \in TOP_{SA} sa_1=sa} (flow_{sa_1, sa_2}) - \sum_{(sa_1, sa_2) \in TOP_{SA} sa_2=sa} (flow_{sa_1, sa_2})$	$\forall sa \in SA$	(7)

The objective function of the scheduling area model is comparable to the one from the BZ flow calculation: here too we minimize linear and quadratic flow functions. The difference is we consider the flows (or exchanges) between scheduling areas rather than bidding zones.

Constraint (6) pro-rates cross border exchanges across the underlying scheduling area flows according to installed thermal capacities. In case both zones only have a single scheduling area, the full bidding zone flow will flow between the scheduling areas. For the model it is important to be provided with thermal capacities, even for these lines, to avoid division by zero problems (albeit the value could just assume a default value like "1", and may not necessarily reflect the installed thermal capacity). ALWG will provide a suggestion for the default value, which will be included in the SCF, and PMB will subsequently populate them into the DB. It can already be confirmed a value will always be provided.

Constraint (7) balances the sum of the SA flows with the sa net position;

Note: for lines where losses apply, the losses need to be appropriately reflected in constraint (6).

Additional constraints that need to be respected:

1. The sum of all flows for the scheduling area lines that represent the same bidding zone line shall match the value from the corresponding zonal line flow. [**note:** through constraint (1) this is necessarily the case, but if in the future changes would be made to (1), this consistency constraint continues to be required];
2. Cross border scheduling area flows shall follow the same direction as the corresponding cross border zonal flows. [**note:** through constraint (1) of the optimization problem above this is necessarily the case, but if in the future changes would be made to (1), this consistency constraint continues to be required]

3.5.3 SEC Backup calculation process (degraded mode)

The NEMO trading hubs flows and Scheduling Area flows sub-problems in Euphemia can be solved by using quadratic programming, as described in sections 3.5.2 and 0, and the existence of a feasible solution is theoretically guaranteed. However, in exceptional cases, the solver may not be able to identify feasible solutions, due to numerical problems that can induce infeasibilities. To deal with such potential problems, a backup calculation process, called degraded mode, needs to be used to compute the Scheduling area and NEMO trading hubs flows. The degraded mode is based on the implementation of a combinatorial heuristic based on simple mathematical operations and is fully independent of the algorithm solver.

For every solution found, Euphemia first tries to compute the scheduling area and NEMO trading hub flows by solving the problem in normal mode. If the flow calculation sub-problem fails to determine scheduling area flows or NEMO trading hub flows, the degraded mode is automatically triggered.

This way a solution that yields a higher welfare will not be discarded if no scheduling area and NEMO trading hub flows can be found, but rather flow calculation will be run in degraded mode. In the end of Euphemia calculation process the following cases can occur:

- A (401) solution with optimal scheduling area and NEMO trading hub flows computed by solving the flows in normal mode;
- A solution with scheduling area and NEMO trading hub flows computed in degraded mode. The use of the degraded mode will be indicated by another solution quality level, and a modified end-message;
- No solution yet and follow exceptional procedures to manage algorithm incidents.

The “degraded mode” algorithm acts directly on the NEMO hub level. From the inter NEMO flow results, the scheduling area results will be inferred, and therefore a strict correspondence between the two will be ensured.

The heuristic consists of two steps, which are explained below. To illustrate its impact, the steps are supported by a very simple example:

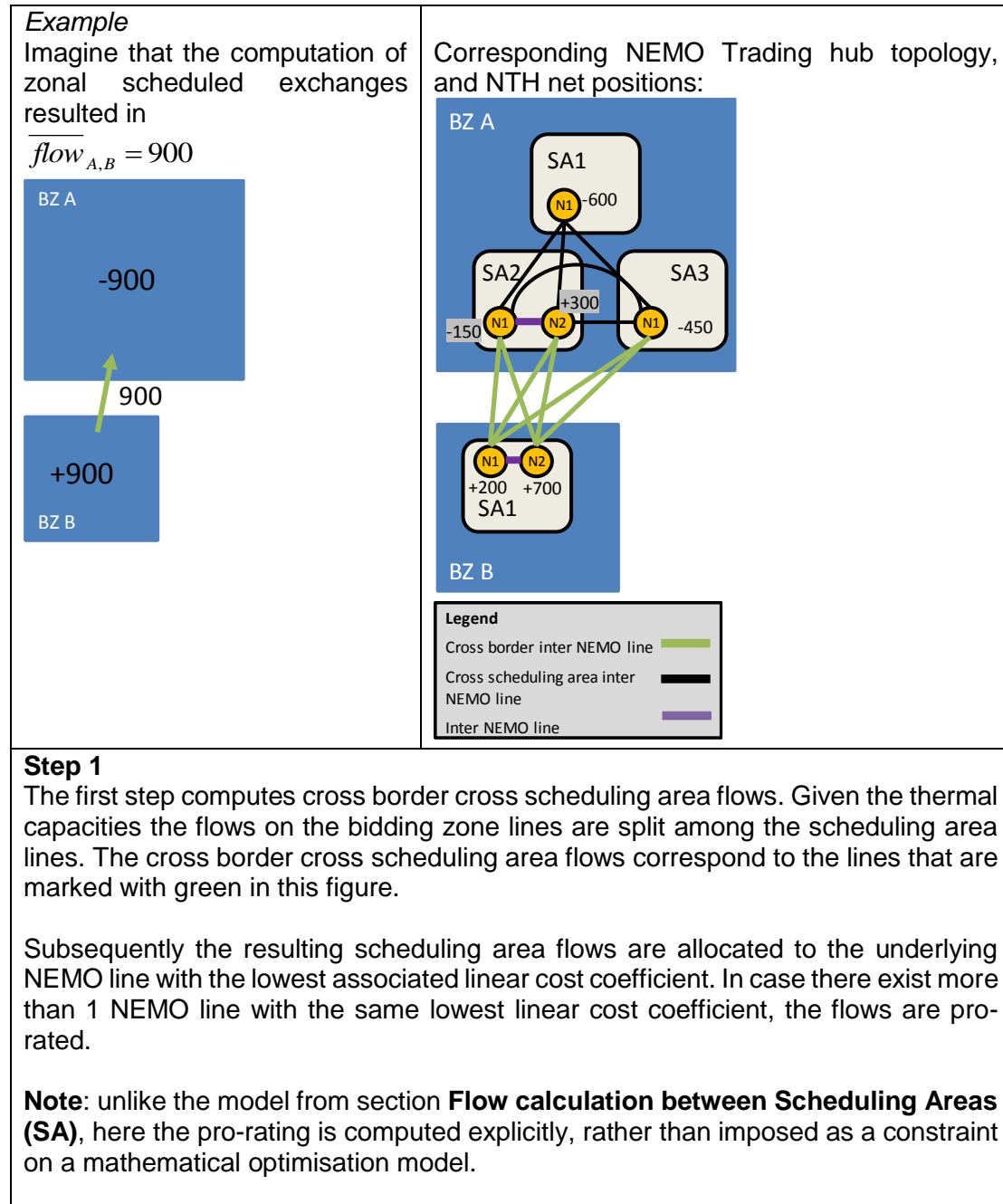

Example

Zonal flow A→B = 900MW
 Thermal capacities:
 SA1-SA2: 700MW
 SA1-SA3 : 1400MW

Pro-rating of scheduling area flows :

$$flow_{sa_1,sa_2} = \frac{700}{700 + 1400} \cdot 900 = 300$$

$$flow_{sa_1,sa_3} = \frac{1400}{700 + 1400} \cdot 900 = 600$$

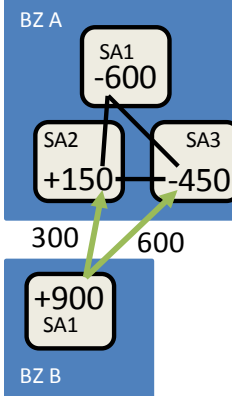

Assume that all cross border inter NEMO lines have identical linear cost coefficients. I.e. the scheduling area flows will be pro-rated amongst them.

From	To	Linear cost coefficient	Lowest?
B.SA1.N1	A.SA2.N1	1	Yes
B.SA1.N1	A.SA2.N2	1	Yes
B.SA1.N2	A.SA2.N1	1	Yes
B.SA1.N2	A.SA2.N2	100	No
B.SA1.N1	A.SA3.N1	100	No
B.SA1.N2	A.SA3.N1	0	Yes

The 300MW between scheduling areas B.SA1 and A.SA2 will be pro-rated across the 3 lines with linear cost coefficient = 1.

The 600MW between scheduling areas B.SA1 and A.SA3 will fully allocated to the line with linear cost coefficient = 0.

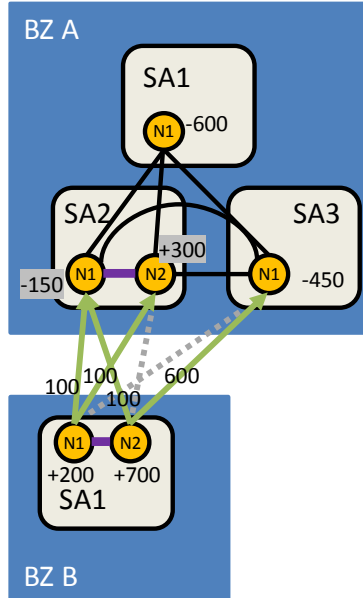

Step 2

The second step computes the inner bidding zone NEMO flows (Cross scheduling area inter NEMO and Inter NEMO flows).

This step will be applied to all bidding zones separately. We use the term inner-BZ net-position to describe the value of the NEMO hub net-position increased by the incoming flows on cross border inter-NEMO lines and decreased by the outgoing flows on cross border inter-NEMO lines.

Example

In the illustration to the right, the net positions for BZ A NEMO trading hubs have been updated accordingly.

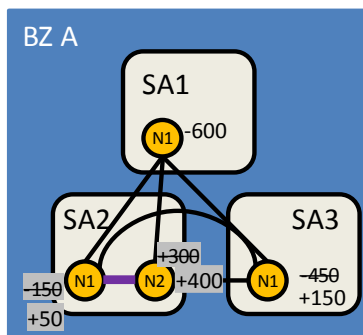

Step 2 (continued)

The heuristic computes the flows on inner-BZ NEMO lines by solving a minimum-cost maximum flow problem. To model the problem, we add a source (s) and a sink (t) node to the bidding zone NEMO topology. We add lines between the source node and all NEMO hubs with positive inner-BZ net position and use the inner-BZ net positions as capacities on these lines. In the same way, we connect the NEMO hubs with negative inner-BZ net position to the sink node. All other lines correspond to inner-BZ NEMO lines, and only the linear cost coefficients are applied.

Example

The RHS illustration shows the resulting topology for our example of bidding zone A. The numbers in black are the capacities (internal lines have infinite capacity). The numbers in red are the associated linear cost coefficients.

Note that the scheduling areas are discarded in the problem, since they impose no internal capacity constraints. As part of this degraded mode algorithm, we will thus discard the SA scheduled exchange calculation step, which considered its own objective with linear and quadratic cost coefficients.

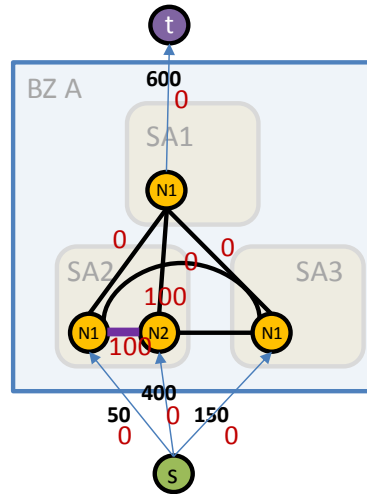

Step 2 (continued)

Given this input, a combinatorial minimum-cost maximum flow algorithm can be used to compute the flows on the NEMO lines.

Example

In our simple example for bidding zone A we can find an answer without an actual algorithm. Since there exist several paths from s to t with length 0, there exists no unique solution and the algorithm will return one of them. I.e. the algorithm may return either of the solutions illustrated to the right, or even a different one still. Only the length of the path (in our example 0) is ensured.

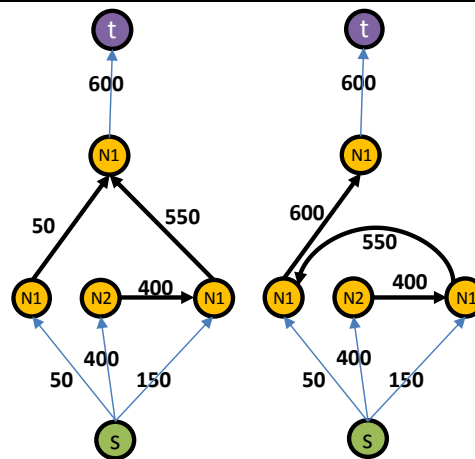

Determinism

In the last step of our example it became apparent that the degraded mode algorithm cannot guarantee the uniqueness of the solution. Please mind the solution shall still be deterministic: if the same zonal solution is found (i.e. all variables, both primal and dual are identical), and the degraded algorithm is called to find a solution, it will consistently find the same (arbitrary in case more than 1 exist) solution.

Scheduling area flows under degraded mode

The cross-border scheduling area flows were already determined. The inner scheduling area flows can now be trivially inferred from the inter NEMO flows. Imagine the second solution from the step 2 example for bidding zone A is returned:

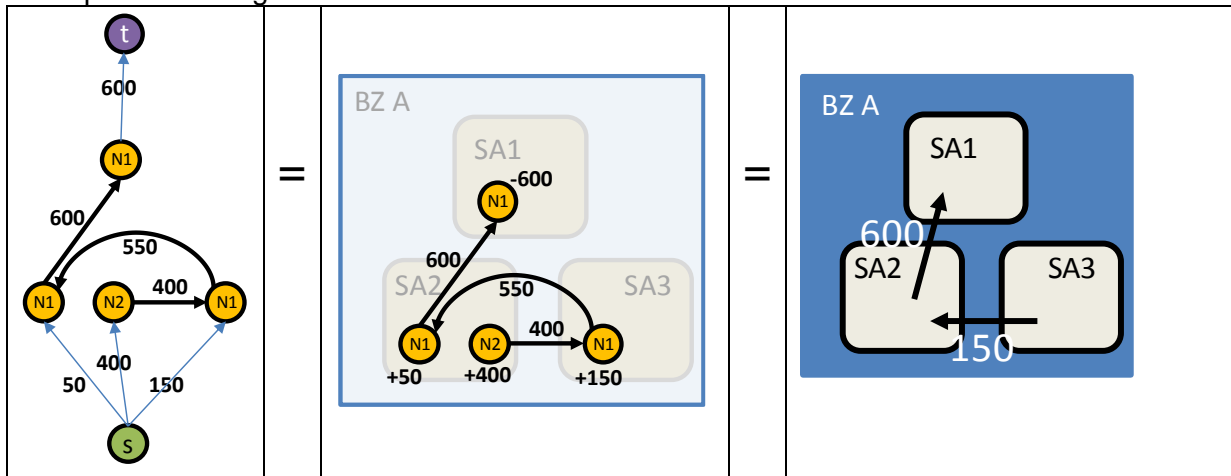

As mentioned above in degraded mode a heuristic computes the flows on inner-BZ NEMO lines by solving a minimum-cost maximum flow problem. The linear coefficients are considered, but the quadratic ones are ignored, as mentioned in the table below. The constraints that are not respected in the degraded mode are described in the table below.

Level	Constraints/requirements respected	Constraints/requirements violated
Scheduling areas	<ul style="list-style-type: none"> Sum of the underlying scheduling area flows matches zonal flow 	<ul style="list-style-type: none"> In the scheduling area flow model the uniqueness of the solution can no longer be guaranteed (as this was implemented through the quadratic cost coefficients, that now are discarded)
NEMO Trading Hubs	<ul style="list-style-type: none"> Sum of the underlying NEMO trading hub flows matches SA flow 	<ul style="list-style-type: none"> Other Inter-NEMO flow calculation objectives are not considered (e.g. net exposure minimization) In the minimum cost - maximum flow problem the quadratic cost coefficients are discarded Inter NEMO flows within the same BZ, but across different SAs, may not necessarily follow the same

		direction as the SA flows
--	--	---------------------------

3.5.4 Rounding solution

Introduction

Euphemia will secure that each NEMO trading hub NTHn will be balanced: the sum of inter NEMO trading hub flows out of NTHn, minus the sum of inter NEMO trading hub flows into NTHn will match the net position of NTHn (up to the configured tolerance).

However, the energy that will eventually be nominated will need to be rounded:

- The NEMO trading hub net positions will need to be rounded to the precision of the bidding zone they are located in;
- The intra bidding zone inter NEMO trading hub flows need to be rounded to the precision of the bidding zone they are located in;
- The inter bidding zone, inter NEMO trading hub flows need to be rounded to the precision of the cross-border interconnector;

Due to the rounding the NEMO trading hubs may no longer be balanced.

Example

We can illustrate this using the case without MNAs. The illustration below focuses on France, for delivery day 3 May 2017, hour 12. The hub nomination needs to be rounded to .1MWh. The border with Italy needs to be rounded to 1MWh. All other borders are rounded to .1MWh. For this specific hour the rounding imbalance was .7MWh.

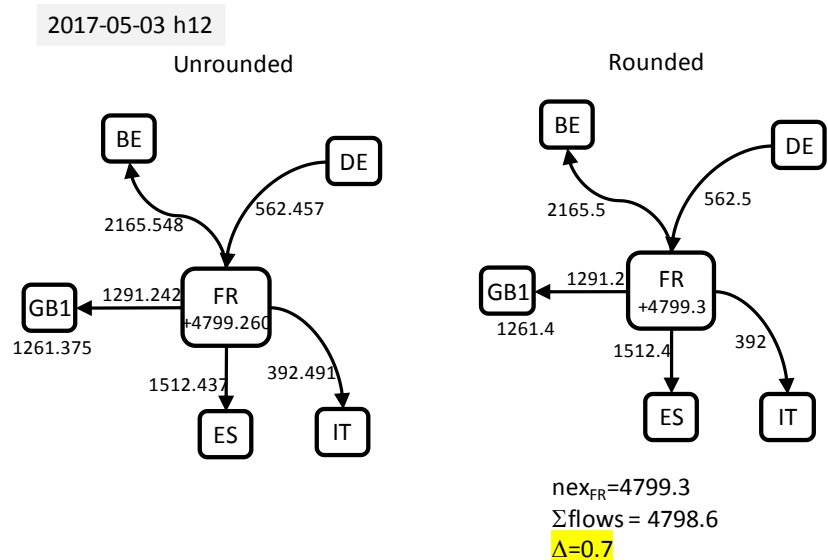

Note: the illustration contains outputs from Euphemia. Mind that pre-MNA rather than using the Euphemia results, CWE TSOs compute the CWE exchanges (i.e. BE-FR and DE-FR) as a post coupling activity. Therefore, the deviation may have been different for the actual production situation.

MNA rounding

The MNA rounding solution shall identify the NEMO rounding residuals and:

- Either distribute the residuals across the NEMOs (“local rounding” solution), or
- Attribute them to a “deviation hub” if one exists in the bidding zone;

The “deviation hub” would be the entity responsible to manage the rounding deviations and would be modelled as a special instance of NEMO trading hub entity.

Finally the rounded results should be made consistent across the BZ, SA and NTH levels. The solution is outlined below:

	Comment
<p>Step 1 The zonal flows are rounded to the precision of the line;</p>	<p><i>The flow could be different on both sides of a line even if there are no losses, because different precisions may be used in the two adjacent bidding zones.</i></p>
<p>Step 2 Deduce rounded net positions for all bidding zones, as the difference between the sum of the rounded outgoing zonal flows and the sum of the rounded incoming zonal flows:</p> $\widehat{NP}_{bz} \leftarrow \sum_{(bz,bz') \in TOP_{bz}} flow_{bz,bz'} - \sum_{(bz',bz) \in TOP_{bz}} flow_{bz',bz}$	<p><i>Here the flow variables should be read as the zonal flows after rounding using the precision of the line end that applies to bidding zone bz</i></p>
<p>Step 3 Deduce the rounding residuals per bidding zone:</p> <ol style="list-style-type: none"> 1. Define rounded net position for all bidding zones as the sum of the rounded NEMO trading hub positions: $NP_{bz} \leftarrow \sum_{sa \in bz.SA} \sum_{nh \in sa.NH} NP_{nh}$ <ol style="list-style-type: none"> 2. The bidding zone rounding residuals are defined as: $\varepsilon_{bz} \leftarrow NP_{bz} - \widehat{NP}_{bz}$	<p>Here the NP_{nh} variables should be read as the NEMO trading hub net positions, after rounding to the precision of their bidding zone.</p> <p>By convention negative residual means the bidding zone is short, positive residual the bidding zone is long.</p>
<p>Step 4a The rounded net position of the deviation hub of bidding zone bz will be set to ε_{bz}. The rounded net positions for the NTHs in bidding zone bz can maintain their initial values.</p>	<p><i>Deviation hub case</i> Outputs will be the allocated deviation (<code>deviationQty</code>) to be recorded for all levels, i.e. in:</p> <ul style="list-style-type: none"> - Preliminary_Results (BZ level); - Preliminary_ResultsSchedulginArea (SA level); - Preliminary_ResultsNEMOhubs (NTH level); <p>The deviation hub will not be explicitly modelled, so no flows to or from the deviation hub are output.</p>

Step 4b

In case bidding zone bz has no deviation hub defined, the rounding residuals will be distributed across the NTHs. ε_{bz} consists of $n = \frac{\varepsilon_{zb}}{NP_PRECISION_{bz}}$ ticks. The n ticks will be distributed one by one to each NTH.

Exception

If a NTH has no orders, it ideally should not be considered in the assignment of residuals. To avoid infeasibilities where there exists no option but to assign the residual to such an NTH, Euphemia shall perform the following input check before exempting the NTH from residuals:

- Each bidding zone shall have at least 1 NTH that does have orders, or
- The capacity to and from this bidding zone is 0.

In case of tie and to avoid bias, the NEMOs will be put in a random order, and ticks will be attributed in that order.

Local rounding solution case

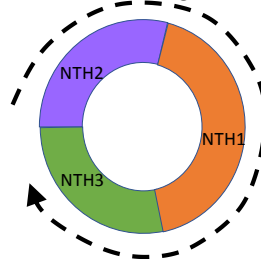

Ticks being distributed across NTHs in a random order. If n is greater than the number of NTHs, we loop back to the first NEMO.

WARNING

If this option is used in a bidding zone, the involved NEMOs should be ready to accommodate the rounding residuals (either into their portfolio allocation, or via other means in case such exist). In case the deviations are tackled via the portfolio allocation process, NEMOs are expected to account for all eventualities:

- Low levels of liquidity in the market;
- Absorbing the theoretical maximum deviation in that BZ (also accounting for the situation where all other NTHs are partially decoupled, hence the full deviation would need to be absorbed);

Finally note that virtual areas will **not** be exempted from the deviations: there exists capacity to and from such bidding zones, and we can't apriori guarantee the existence of a feasible solution. A zonal example would be:

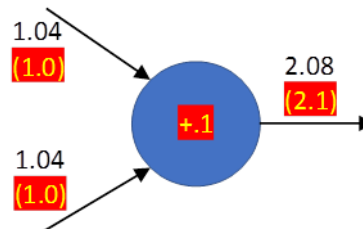

If the blue area is a virtual one, the unrounded flows are balanced, but after rounding (in red) a position of .1MWh (ergo a rounding residual of -.1MWh) emerges.

	Comment
	MNAs that make use of virtual areas are expected to put in place appropriate solutions to cope with such deviations too.
<p>Step 5: Rounded inter zonal, inter scheduling area inter NTH flows</p> <ul style="list-style-type: none"> a) For all inter NTH inter scheduling area lines that cross a zonal border¹⁰, round the inter NTH flows to the nearest tick; b) Compute a rounding residual as the difference between the rounded zonal flow and the sum of the rounded inter zonal, inter scheduling area, inter NTH flows; c) Distribute the residual ticks one by one to each inter NTH lines, in the order given by the line IDs 	<p>Note: the choice for which NEMO lines to allocate the rounding residuals to is done using the line id. The reason not to consider a more fair (e.g. random) allocation here is that individual NEMOs are not impacted: their net positions are already fixed, and it is like squeezing a balloon: small change on the inter NEMO XB flow translates to a corresponding small change on the internal zonal NEMO flows.</p>

¹⁰ If there are > 1 scheduling areas that cross the same zonal border, they need to be processed one by one, they can't be aggregated. Example: FR→DE has 2 scheduling area borders: Rte→Amprion, and Rte→Transnet. First all inter NTH lines between Rte and Amprion will be processed, subsequently all NTH lines between Rte and Transnet will be processed.

Step 6: Rounded intra zonal inter NEMO flows

For each bidding zone bz:

- a) The inter NEMO trading hub flows within bz are rounded to the closest bidding zone tick;
- b) Define the following max flow problem¹¹:
 - Each NEMO trading hub in the bidding zone is represented by a node;
 - The deviation hub (if one exists) is represented by a node;
 - Additional source (s) and sink (t) are defined;
 - The NEMO trading hubs and the deviation hub are linked by edges according to the NTH topology, plus links between all NTHs to the deviation hub (if one exists). The capacity on these edges is infinite;
 - For each NEMO trading hub retrieve the residual position as the difference between the rounded net position and the rounded outgoing and incoming flows;
 - Under step 4a (a deviation hub case) the original deviation remain + an opposite deviation now exists for the deviation hub;
 - Under step 4b (a local rounding solution case) the original deviations have been altered through the allocation of the residual ticks;
 - Link all NEMO trading hubs with positive residual position to the source, and the others to the sink. The capacity on the links is given by the residual position of the corresponding NEMO trading hub. It represents the maximum amount of

Comment: Mind that the rounded net positions to be used in the rounding process for the management of inter-NTH flows will depend on the actual implementation of the way deviations will be provided:

- If a deviation hub is explicitly implemented with a topology, then the rounded net position to be considered for hubs shall be the “rounded unrounded net positions”;

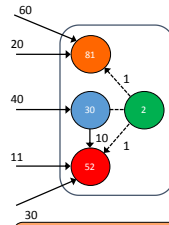

- Explicitly create lines associated to the deviation hub (i.e. shall be present in the SCF)
- In the results, the flows associated to the line explicitly defines the residual quantities to be nominated
- No deviation value needs to be reported in addition to the rounded net position for each NEMO trading hub

Here the flows are consistent with the provided net position (ex: $60 + 20 + 1 = 81$ for the NEMO hub in orange)

- If the explicit definition of a deviation hub is now dropped, and the deviation value applying to a NTH is provided as a separate column, then the inter-NTH flows shall be computed using NTH rounded net positions equalling to the “rounded unrounded net positions + the NTH attributed deviation” (i.e. back to initial n-Side’s proposal)

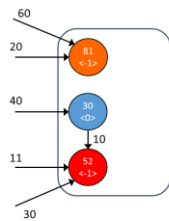

- Do not create any line between the deviation hub and the local nemo hubs
- However, an deviation value shall be provided additionally to the (unchanged) rounded net position
- Here indicated between '<.>'
- As we assume that this deviation shall only be provided by/to the deviation hub, the deviation value associated to a NEMO hub equals the flow transiting in the non-explicitly defined lines
- The deviation hub net position shall equal the sum of negated deviation values of local NEMO hubs

Here the flows are not consistent with the provided net position if you ignore the deviation (ex: $60 + 20 \neq 81$ for the NEMO hub in orange)

	Comment
flow that can pass through an edge.	
Step 7: the rounded intra zonal inter scheduling area flows follow directly from the intra zonal inter NTH flows obtained in step 6.	

3.6 Solution validation

As explained in section **Euphemia perspective on sequence of the coupling calculation process**, Euphemia will consider its different outputs in subsequent steps:

1. Results (prices, order acceptance statuses, net positions and flows) at the bidding zone level;
2. Results (net positions and flows) at the SA and NTH level;

In section **SEC Backup calculation process (degraded mode)**, the SEC degraded mode is introduced: in case zonal results are available, but Euphemia runs into problems in the SA or NTH flow calculations, it will automatically trigger this degraded mode, to still find SA and NTH results.

Only if all the required outputs for a solution are available will N-Side commit the solution to the database. Euphemia will indicate the solution quality in its solution log:

- OK: all constraints have been met against technical tolerances;
- TECH: all constraints have been met against decoupling tolerances, but at least one constraint was not met against technical tolerances;
- DECPL: at least one constraint was not met against decoupling tolerances;
- OK_BUT_GME_lines: OK quality for all constraints, except on the borders between PUN bidding zones;
- **New:** OK-degraded-SEC: OK quality, but SEC results obtained with degraded mode algorithm
- **New:** TECH-degraded-SEC: TECH quality, but SEC results obtained with degraded mode algorithm
- **New:** DECPL-degraded-SEC: DECPL quality, but SEC results obtained with degraded mode algorithm

Consequently whenever an OK solution is logged to the DB, all required outputs will necessarily be present. PMB will not have to cope with the situation where only partial results (e.g. only BZ results) are available.

The quality of the accepted solution will be reflected by the terminating message code Euphemia will write the algorithm_event_log. New message codes will need to be agreed for the new solution qualities (e.g. OK-degraded-SEC = 431; TECH-degraded-SEC=432; DECPL-degraded-SEC=335, i.e. same as usual + 30).

3.7 Change Control

¹¹ The maximum flow problem is to route as much flow as possible from source to sink

The thermal capacities will be managed in the PCR Shared Configuration File (SCF). If TSOs want to make changes to their thermal capacities, this will impact PCR, and consequently need to be put under common NEMO + TSO change control.

NEMO trading hub lines will be configured in SCF, in a way that reflects the different scenarios needed according to the MNA Projects and under common NEMO + TSO change control.

The cost coefficients for zonal lines (both quadratic and/or linear), are provided as an input by TSO and NEMOs, and are jointly agreed in MRC and validated through the MRC algorithm TF under common NEMO + TSO change control.

4. Procedures

4.1 Normal Procedures

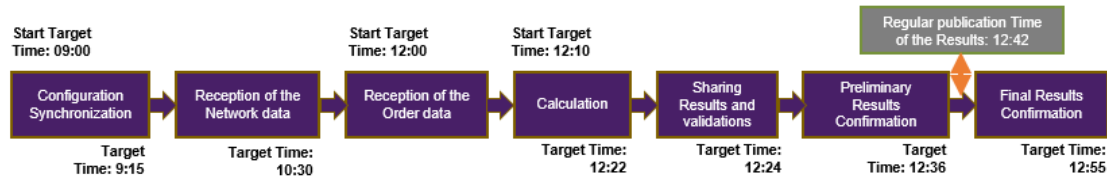

Current Market Coupling Session process

In the current Market Coupling Session process, the Calculation step is set to 12 minutes: 10 minutes of Euphemia calculation + 2 minutes for reading input data and writing output data. The target time for this step is 12:22.

The Results Sharing step, where the Coordinator PMB distributes the results to the Cloud, takes 2 minutes and the target time is 12:24. The next step is the Preliminary Confirmation of the Results, where every PX has 12 dedicated minutes for checking the Results. The target time for this step is 12:36.

The regular publication time is 12:42. In normal days, the margin between the end of the Preliminary Confirmation and the publication time is 6 minutes.

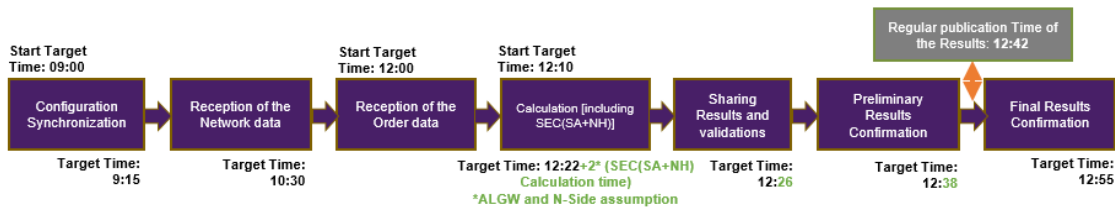

Market Coupling Session process with MNA

For the MNA implementation, the Euphemia calculation will be extended 2 minutes¹² to host the Scheduling area and Nemo hub level flow calculations in the main Calculation run. The whole Calculation step will take 14 minutes. Consequently, the target time for the Results Sharing and the Preliminary Results Confirmation steps will be delayed 2 minutes (to 12:26 and 12:38 respectively).

The margin between the end of the Preliminary Results Confirmation and the regular publication time will be reduced from 6 to 4 minutes. The regular publication time will remain 12:42.

After the publication of the Results, each PX has the possibility to validate them with external parties (TSO, market participants, etc.) in the Final Results Confirmation step. As the regular publication time will not be affected, neither will the Final Confirmation times.

¹² n-Side and PCR ALGW assumption

4.2 SEC Degraded Mode

Euphemia Calculation may encounter issues when trying to find a valid solution within the Calculation Time Limit. If the PCR Coordinator does not find a valid solution, an Incident Committee is immediately triggered and the Algorithm Provider is invited.

If the problem is encountered when performing the Scheduling area and Nemo hub level flow calculations, the "Degraded Mode" will be automatically triggered, and the code of the solution, when the calculation will have finished, will indicate that situation.

The Algorithm Provider, who is invited to the Incident Committee, will connect to the Coordinator's machine in order to try to solve the issue and find a proper solution.

If the problem persists in the Coordinator's Calculation but one PXs finds a valid solution, a Coordinator switch between the Coordinator and the PX that found a solution will be performed.

If the backup actions do not solve the issue before the Full Decoupling Deadline, the Full Decoupling will be declared and the whole PCR area will be decoupled.

It is important to highlight that in case of exceptional situations during the Market Coupling Session, if a new calculation needs to be performed, the new Calculation will also include the 2 additional minutes to perform the Scheduling area and Nemo hub level flow calculation. In total, the whole Market Coupling process will need 4 more minutes to be completed, which increases the risk of Full Decoupling.

4.3 Decoupling Procedures

According to information retrieved from Capacity Calculation Region (CCR) Fallback methodologies, PCR MNA solution needs to handle following main decoupling scenarios.

1. Decoupling a single line / connection from PCR.
2. Partial decoupling of a NEMO in corresponding Bidding zone(s) from the PCR cloud.
3. Regional decoupling of selected region / Bidding zones from the PCR cloud.
4. Full decoupling of all PCR NEMOs from the PCR cloud.

Decoupling a single line can be performed by the NEMO who is responsible of sending the corresponding line capacity to PCR, by sending new network data file with zero capacity for the corresponding line. Existing procedures apply.

Full decoupling will still in the future be decoupling of all PX systems / Virtual brokers from each other and from the PCR cloud. Existing procedures apply. After full decoupling of PCR, regional fallback processes are followed and in some regions this requires regional coupling to be arranged within the corresponding NEMOs.

Partial decoupling of NEMO Trading Hub(s) and NEMO(s), as well as regional decoupling of Bidding zones can all be performed with same PMB functionality. PMB Partial Decoupling GUI will allow coordinator to decouple selected Virtual broker(s) and underlying NEMO Trading Hub(s). PCR Virtual brokers of each NEMO will be configured to support all CCR Fallback scenarios according to decisions done in local MNA projects amongst NEMOs and TSOs. Thus, depending on the region, there can be either one or multiple NEMO Trading Hubs configured for NEMO's Virtual broker. When a virtual broker is decoupled from the PCR cloud, corresponding NTH(s) order data is replaced with decoupling order data values (usually zero values). In case all NTHs from a

bidding zone are decoupled, in addition to the decoupling order data values, also the corresponding interconnection capacities towards the Bidding zone are replaced with decoupling capacity values (usually zero).

Details of possible use of decoupled NTH as transit hub for Inter Nemo Flow calculation are still under discussion.

Example: Decoupled NTHs are on the edge of the topology and whole region is decoupled. Flow calculation is still performed with same topology, but since both zero order data and capacities apply for these edge Bidding zones and NTHs, the NTHs are not used as transit.

The solution shall be able to accommodate with interim periods where MNA is not in place on all borders of a given bidding zone: in such interim periods, there could be specific cases for decoupling, where one of the NEMOs in a BZ could hold temporary the shipping function for some borders of its BZ.

In case only one/some Virtual broker(s) and NTH(s) of a NEMO are decoupled, NEMO is still able to receive the PCR results with normal procedures via PMB.

In case a NEMO is decoupled from the PCR and therefore it is not able to receive the PCR results with normal procedures via PMB, coordinator will distribute the results with backup procedures (FTP).

The supporting documents reflecting the Capacity Calculation Region (CCR) specific Fallback methodologies and for clarifying the decoupling scenarios will be shared as soon as they are complete and finalized.

5 PMB requirements

The PMB shall be accommodated to allow multiple NEMOs within one bidding zone. PMB shall allow multiple NEMO trading hubs and multiple scheduling areas to be configured for each bidding zone. Configurations are done in Shared Configuration File – as all other already existing configurations. NEMOs will send their orderbooks for NEMO trading hubs and PMB will forward this information to Euphemia. MNA also introduces changes to network constraints data submission and corresponding changes are implemented to PMB.

In addition to existing net positions and flows for bidding zones, expected additional output in MNA solution will be related to NEMO trading hubs and Scheduling areas. NTH net positions and flows between configured NTHs will be available in the result document, as well as the rounding deviations (where applicable).

Each bidding zone line must have at least one underlying scheduling area line, and each scheduling area line needs to have at least one underlying NEMO trading hub line. NEMO lines are defined in the same direction as the corresponding cross-zonal line, and in each bidding zone, in the NEMO hub topology each NEMO hub is connected to another NEMO hub via at least one route. The lines between NEMO Hubs can be freely configured as many as needed as described above for determining the proper quantity to be exchanged between NEMO trading hubs. The setup of NEMO trading hubs and NEMO trading hub lines shall be able to accommodate with interim periods where MNA is not in place on all borders of a given bidding zone.

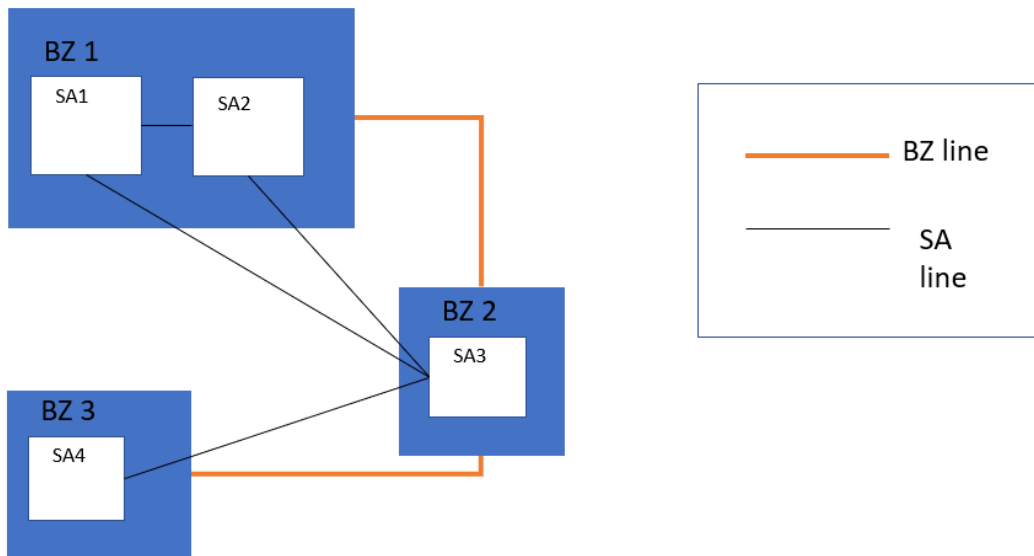

Figure 10 Modelling the BZ and SA lines

PMB shall also be able to provide the scheduling area results. The scheduling areas will be mapped into the Shared Configuration File for the entire topology, but with a new “flag and filter” feature implemented, so that the scheduling area net positions and scheduling area line flow results are written for only those areas and lines in the topology which TSOs have required.

All changes that needs to be implemented to PMB are designed to cause minimum impact on the NEMOs and local trading systems. This is done in order to avoid unnecessary impact on NEMOs acting in regions where multiple NEMOs or multiple Scheduling areas are not in place.

5.1 Shared Configuration file changes

To enable multi NEMO solution, various changes need to be implemented to Shared configuration file. These include a change to capacity cross-check functionality, addition of NTHs, NTH lines, SAs and SA lines.

NEMO trading hubs will be configured in SCF. NEMO's virtual broker and data providing system will be configured against NTHs. Currently, prior MNA, this configuration is on bidding area level. Curve form will also be configured on NTH level (currently on bidding area level). Relation from BZ and SA to NTH will be also configured on NTH level.

NEMO trading hub lines will be configured in SCF, in a way that reflects the different scenarios needed according to the MNA Projects. In order to take into account different MNA arrangements that can differ per countries, it shall be possible to handle different configurations in two adjacent bidding zones.

Example (for illustration):

- Great Britain : two bidding zones 10Y1001A1001A57G (Nord Pool bidding zone in GB), 10Y1001A1001A58E (EPEX bidding zone in GB), each bidding zone has its own NEMO trading hub (one);
- France : one FR bidding zone 10YFR-RTE-----C, and two NEMO trading hub (Nord Pool, EPEX).

In such a case, Euphemia shall be able to calculate bidding zone flows between FR bidding zone and Nord Pool bidding zone in GB, as well as (depending on shipping arrangement between NEMOs):

- Either inter-NEMO flows between the two NEMO trading hubs in FR bidding zone and the NEMO trading hub in Nord Pool bidding zone in GB (two NEMO trading hub lines);
- Or inter-NEMO flow between the EPEX NEMO trading hub in FR bidding zone and the NEMO trading hub in Nord Pool bidding zone in GB (one NEMO trading hub line).

Scheduling areas will be modelled for the entire topology, similarly as balancing areas have been modelled since the PMB go-live. SA relation to BZ will be configured on SA level. Also the configuration if results are needed for the SA, is configured here.

Scheduling area lines will be configured in SCF. The linear and quadratic coefficients and thermal capacities will be configured on this level. Also the configuration if results are needed for the SA line, is configured here.

The one-to-one relationship between a NEMO and its corresponding CCP (whether internal or external) is configured in the SCF. This information will allow among others Inter Nemo Flow Calculation.

5.2 CZC submission

As it has been decided that in MNA any NEMO will be able to submit the cross-zonal capacity data, this will require changes to PMB's network data cross-check functionality. Actual network data document schema and data flow from local trading systems to PCR cloud (PCR perspective) will remain unchanged.

The different submission modes are described in the following subchapter.

5.2.1 Cross-check modes

Cross-check behaviour of cross zonal capacity constraints has to be redesigned due to the possibility to have more than 2 NEMOs as data providers being responsible for the specific cross zonal capacity constraints data. This applies to both ATC and flow-based type of capacity constraints data.

SCF will be modified to enable possibility to fill any number of virtual brokers into the columns which define responsibility for the data of the specific connection (ATC or flow-based).

Cross-check validation is performed every time the network data message is received and has passed all the network data validations.

When multiple data and versions are provided by virtual brokers, the history of the cross-check is not recorded. Only the last state of the cross-check is stored/displayed. This behaviour remains as is in PMB9.

5.2.1.1 Single mode

The Single submission mode means, that there is only one virtual broker responsible for the data of the cross zonal capacity constraints (ATC or flow-based).

Connections with single submission mode are not displayed in the Cross-check screen on the PMB GUI.

5.2.1.2 Alternate mode

The Alternate submission mode is available for both ATC and flow-based connections and will be changed in following way due to MNA.

Data submission possibilities, when multiple virtual brokers have been configured to be providing the data:

- At least one of the VBs, configured as data providers in first group, has to provide data for the connection, but more than one of them can provide the data
- If one or more VBs is configured as data providers in second group, at least one of them has to provide data for the connection

If there is data for the connection provided by more than one virtual broker, the cross-check validation is performed between all VBs which have provided the data for the connection in their last validated network data message (highest validated version).

- data are the same - status of the cross-check for this connection is marked as VALIDATED in the GUI
- data are not the same - status of the cross-check for this connection is marked as FAILED

If there is data for the connection provided by only one or more Virtual brokers configured in first group, but one or more virtual brokers are configured in second group

- status of the cross-check for this connection is marked as ALERT in the GUI
- If there is data for the connection provided by only one or more VBs configured in second group but one or more VBs are configured in first group
 - status of the cross-check for this connection is blank in the GUI and is waiting on the data from first group VB

If there is data for the connection provided by only VBs from first group and no VBs are configured in second group this connection is marked as VALIDATED in the GUI.

5.2.1.3 *Cross-checked mode*

The cross-checked submission mode is available for ATC connections and the possibilities are

- each virtual broker of the first group can provide data for the connection
- each virtual broker of the second group can provide data for the connection

The Cross-check validation is performed between all virtual brokers which have provided the data for the connection in their last validated network message (highest validated version).

- data are the same, but not all configured Virtual brokers have submitted the data - status of the cross-check for this connection is marked as ALERT in the GUI, "Ignore" button is available and can be pushed manually by Operator of each PMB
- data are not the same - status of the cross-check for this connection is marked as FAILED, the button "Error Detail" is available, after click on this button the table of the connection data issues is displayed
- data are the same and all configured Virtual brokers have submitted the data - status of the cross-check for this connection is marked as VALIDATED in the GUI

5.2.1.4 Decoupling submission

The decoupling submission mode might not be required in the future, but will be kept in the system. Currently the decoupling submission mode allows PMB to set decoupling values for connection when non-data providing Virtual broker is decoupled. This will be allowed in the future also, but now supporting also multiple Virtual brokers to be configured.

- At least one of the Virtual brokers, configured as data providers in first group, has to provide data for the connection, but more than one of them can provide the data
- None of the Virtual brokers configured as data providers in second group, can provide data for the connection

In case all the virtual brokers which are configured in the second group, are decoupled, the decoupling values are set for the connection.

Cross-check validations are similar to the Alternate submission mode. If there is data for the connection provided by more than one virtual broker (configured in first group), the cross-check validation is performed between all VBs which have provided the data for the connection in their last validated network data message (highest validated version).

- data are the same - status of the cross-check for this connection is marked as VALIDATED in the GUI
- data are not the same - status of the cross-check for this connection is marked as FAILED

5.2.2 Network data validation GUI

List of all cross-checks is accessible from the PMB GUI. The list of cross-checks is redesigned due to ability to display more virtual brokers in one cell of the table. All responsible virtual brokers are listed in the GUI with information of received data.

5.3 Order data submission

As input data from NEMOs will be collected on NEMO trading hub level in the future MNA solution, the local trading systems of individual NEMOs need to be adapted accordingly. This applies only to those NEMOs which intent to send order books on bidding zone which has more than one scheduling area.

For bidding zones where exists only one scheduling area, the implementation is kept untouched from current PCR PMB interface and NEMOs can send order data using existing Bidding area - element in the schema. PMB will relate the received order data information (sending NEMO, bidding zone) to the correct NTH based on the SCF configuration.

For bidding zones where there are multiple scheduling areas, the NEMOs need to send in the order data with scheduling area -information. Thus, sending the orders per bidding zones and scheduling areas. PMB will then relate the received order data information (sending NEMO, bidding zone, scheduling area) to the correct NTH based on the SCF configuration.

Submitted order data will be anonymous similarly as it currently is.

5.4 Interface changes towards algorithm

Due to the MNA setup the algorithm interface between PMB and Euphemia will change. The mapping from algorithm interface to SCF, order data and results document content is changed.

Reference between NEMO and corresponding virtual broker / data providing system is created. Reference between NTH, bidding zone, NEMO and curve form is created.

5.4.1 Order Data

The NEMOs will send in order data for NEMO trading hubs, not for bidding areas as is in current PMB version prior MNA. All order types in algorithm interface will be referring to NTH, instead of current bidding area reference. Order data for bidding zones is aggregated from the NTH order data by Euphemia (and described in chapter 3).

5.4.2 Results

Results section is extended to be able to contain results for NEMO trading hubs (not aggregated results), NTH flows/net positions, Scheduling areas net positions and Scheduling area flows, in addition to existing results (prices, net positions, flow) at bidding zone level. Euphemia writes all available results to algorithm interface, but PMB will write Results document content based on the given SCF configuration.

5.4.3 Tie break rules between blocks

Criterion #1 is the last modification time. For this, the time stamps need to be aligned. Criterion #2 is the hash. The hash calculation will be done on the Euphemia side.

5.5 Show Results GUI

The PMB GUI needs to be modified in order to display the NTH results. NEMO Hub Results bookmark is added.

5.6 Results document

The Result document is extended to provide information about NTH net positions, NTH flows, scheduling area net positions and scheduling area flows in addition to existing results (prices, net positions, flow) at bidding zone level. Also the rounding deviations (where applicable) will be provided in the result document.

Design is agreed in such a way that causes minimum changes to NEMOs' local trading systems. Thus, NTH results are added under bidding zone results and can therefore be omitted by NEMOs which are the single NEMO on corresponding bidding zone.

Due to this same reason, all individual order results (block orders, complex orders, merit orders) are kept under bidding zone results and are now referred to corresponding NTH.

5.7 Identification codes of BZ, SA, NH and Tie lines

The identification codes for the BZ will be the official ENTSO-E EIC code. The identification codes for SA:s outside the German region will be the same as the identification code for the BZ. For the SA:s inside the German region, official ENTSO-E EIC codes will be used.

The NH identification codes will be internal, PCR invented codes.

5.8 Changes in PBM due to decoupling

In the future PCR MNA solution it must be possible to decouple either

1. one PX system / Virtual broker with all its NEMO Trading Hubs in corresponding Bidding zones,
2. all PX systems / Virtual brokers which have NEMO Trading Hubs in selected region / Bidding zones
3. fully decouple all PCR NEMOs from each other or
4. decouple a single line.

Decoupling a single line can be performed with procedures, NEMO to send zero capacity for the line, and doesn't need changes to PMB functionalities.

Full decoupling functionality doesn't need any changes due to MNA decoupling scenarios. Full decoupling will still in the future be decoupling of all PX systems / Virtual brokers from each other and from the cloud.

PMB functionality for partial decoupling will be changed to decouple Virtual brokers and corresponding NEMO Trading Hubs, not Bidding Areas as PMB does today. Decoupling the Virtual broker sets decoupling order data values (usually zero) to the decoupled NTHs. In case all NTHs from corresponding BZ(s) are decoupled, the decoupling capacity values are set to the interconnections.

More details about PCR decoupling procedures in chapter 4 above.

ANNEX 3 - List of comments received

Question	Organization	Comment	All TSO Response
<p>Please provide us with general comments on the proposed Methodology for calculating Scheduled Exchanges resulting from single day-ahead coupling.</p>	<p>EDF SA</p>	<p>EDF wishes to recall that If stakeholders are consulted to provide feedbacks and inputs, TSOs should make their best efforts to explain in a pedagogical way what is the context and the objectives pursued by TSOs to understand the purpose of a common Scheduled Exchanges calculation methodology and its impact on market participants' activities. Therefore, an updated version of the explanatory notes published in December 2016 when the first version of the two methodologies was submitted to NRAs should have been published together with the new methodology proposals in order to provide full information to stakeholders.</p>	<p>TSOs remind that the timeframe was very short between the letter from NRAs (25th of September 2017) to resubmit the proposals and the start of the public consultation (5th November 2017). In addition, a stakeholder workshop was organized during the public consultation to answer all stakeholders' questions and to explain more the context of the proposal.</p>
<p>Please provide us with your specific comments on Article 7: Calculation of Scheduled Exchanges</p>	<p>EDF SA</p>	<p>EDF wishes to draw TSOs' attention on the application of the intuitiveness scheduling restriction for the calculation of Scheduled Exchanges in the CCRs where the Flow Based capacity allocation approach is applied. At present, situations where the market coupling algorithm would lead to net positions that could not result from (virtual) exchanges occurring from low price areas to high price areas are avoided through the application of an "intuitive patch". Nevertheless, if TSOs decide in the future to introduce a "plain" Market Coupling where non-intuitive situations are allowed (to achieve greater socioeconomic welfare), it is not clear whether the proposed intuitiveness scheduling restriction could lead to Scheduled Exchanges that would be inconsistent with the Bidding Zones Net Positions resulting from the day-ahead market coupling.</p>	<p>TSOs acknowledge the feedback from EDF SA on the intuitiveness.</p>